



CBT

TUBELESS

VERTICAL STEAM BOILER
10 – 30 HP

Reliable Steam, Premium Performance

High-quality steam, high fuel efficiency, low electrical energy consumption, and low emissions – all of this is delivered in a vertical tubeless boiler design to effectively and reliably meet your steam process requirements.

The Cleaver-Brooks Tubeless (CBT) boiler features thick pressure vessel plates that exceed ASME code requirements. The CBT has undergone exhaustive life-cycle testing to ensure reliability and longevity. The side-mounted burner arrangement allows for a large steam space to deliver exceptional dry-quality steam, even at low-pressure operation. The high-density, highly resilient insulating refractory minimizes thermal losses while helping maintain its compact footprint. Convenient hand-hole access and a removable burner cover enhance the CBT's serviceability.

The integrated burner and controls keep the CBT operating at peak efficiency. Multiple burner and control options are available to suit your application needs. For optimal operational efficiency and control, the full-modulation, low-emission premix burner with 1:1 fuel-air ratio control and Falcon controller is available. The Falcon control includes built-in lead-lag functionality for systems with multiple CBT boilers.

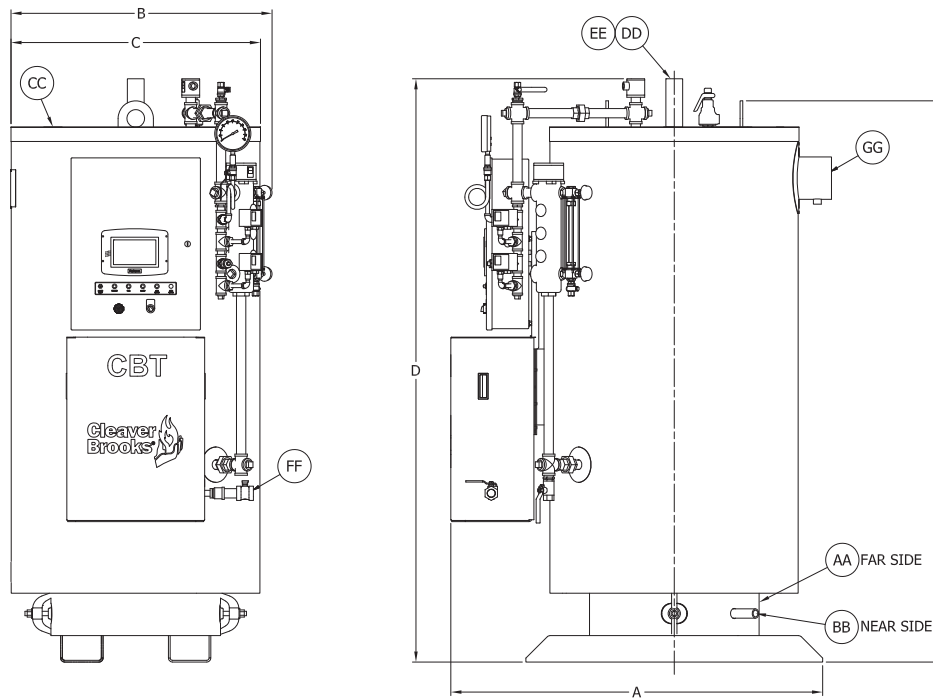

| DIMENSIONS - INCHES | | BOILER HORSEPOWER | | | | |
|--------------------------------|----|-------------------|-------|-------|-------|-------|
| | | DIMENSION | 10 | 15 | 20 | 25 |
| Overall Length | A | 52.5 | 52.5 | 62 | 62 | 64.5 |
| Overall Width | B | 37 | 37 | 46.5 | 46.5 | 49 |
| Minimum Width | C | 35.5 | 35.5 | 45.5 | 45.5 | 48.5 |
| Overall Height | D | 83 | 83 | 87 | 87 | 90.5 |
| Minimum Height | E | 79.5 | 79.5 | 84 | 84 | 87.5 |
| BOILER CONNECTIONS - INCHES | | | | | | |
| Feedwater | AA | 0.75 | 0.75 | 1 | 1 | 1 |
| Drain / Blowdown | BB | 1 | 1 | 1 | 1 | 1 |
| Surface Blowoff | CC | 0.75 | 0.75 | 0.75 | 0.75 | 0.75 |
| Steam Outlet (150# Only) | DD | 2 | 2 | 2 | 2 | 2.5 |
| Steam Outlet (15# Only) | EE | 3 | 3 | 4 | 4 | 4 |
| Gas Train Inlet | FF | 1 | 1 | 1 | 1 | 1.25 |
| Stack O.D. | GG | 6 OD | 6 OD | 6 OD | 6 OD | 8 OD |
| BOILER WEIGHTS - LBS | | | | | | |
| Approx. Shipping Weight (150#) | | 2,350 | 2,350 | 3,850 | 3,850 | 4,350 |
| Approx. Shipping Weight (15#) | | 2,150 | 2,150 | 3,675 | 3,675 | 4,175 |



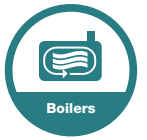

Premium Vertical Tubeless Boiler

The best value for your operation

For more than 85 years, Cleaver-Brooks has been designing, engineering and manufacturing integrated boiler solutions. Cleaver-Brooks engineers have taken the industry-proven tubeless concept while utilizing the latest computer-aided modeling tools to deliver both high efficiency and reliability in this compact, vertical steam boiler. Available for both high-pressure and low-pressure steam systems, the CBT will produce reliable, dry-quality steam for any process.



CBT

10 – 30 HP

Features and Benefits

- Robust tubeless pressure vessel designed for reliability and longevity
- Large steam volume for exceptional dry-quality steam – both high- and low-pressure operation
- Up to 84% efficiency and 5:1 turndown
- 15# and 150# ASME designs
- Flexible burner options:
 - Natural gas or propane
 - From simple on-off to full modulation
 - Standard burner or low-emission premix
- Full-modulation premix burner includes PID set-point control with built-in lead-lag functionality and touchscreen interface
- Side-mounted burner for ease of serviceability
- cULus Listed
- Control trim and gas train are ASME CSD-1 compliant
- Available in skid-mounted steam solutions



Intelligent, Integrated Controls

The Cleaver-Brooks Falcon is a proven boiler-burner management control that provides an intuitive operator interface featuring integrated burner sequencing, trending, flame safety, modulation, alarms, lockout and much more, ensuring your boiler system operates at peak efficiency while providing necessary safety and reliability.

The Cleaver-Brooks Falcon control with integrated lead-lag optimizes steam plant efficiency in multiple boiler systems. It can communicate with your facility monitoring system and process controls, enabling effective system management.

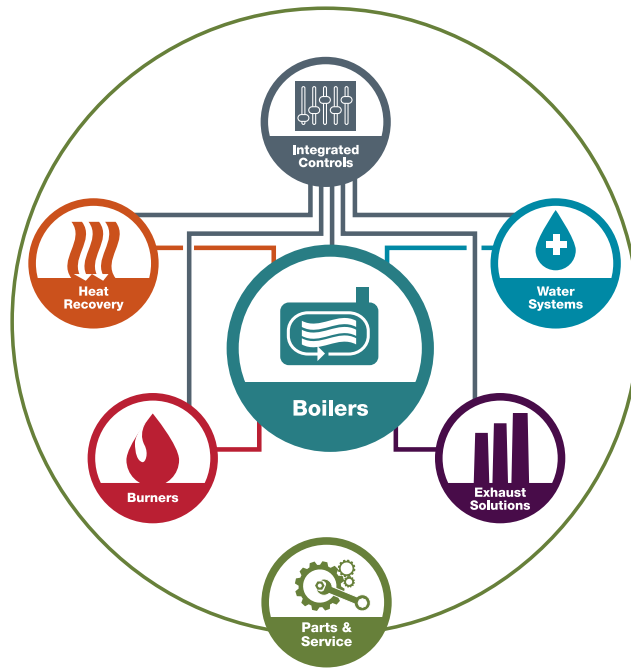

Providing energy-efficient, environmentally friendly boiler room solutions

Cleaver-Brooks is one of only a few boiler room solution providers in the world to operate a dedicated research and development facility. Having pioneered several industry-leading technologies, we remain just as committed today to introducing technology and products that enable a more energy-efficient and environmentally friendly generation of steam and hot water.

We distribute our products through the Cleaver-Brooks Representatives Association, or CBRA, an alliance of independently owned and operated companies that provide boiler room products and service. CBRA companies can be counted on to provide Cleaver-Brooks products and parts, engineering support, customer training, technical service and system maintenance. To find a CBRA representative near you, please visit cleaverbrooks.com/rebs.



221 Law Street • Thomasville, GA 31792 USA
 229-226-3024 • 800-296-4110 • info@cleaverbrooks.com
cleaverbrooks.com