

7

6

5

4

3

2

1

MAJOR COMPONENTS	
1	Control Panel
2	Entrance Panel
3	Blower Motor - 50 HP
4	Air Compressor - 7.5 HP
5	Combustion Safeguard Control - CB780E
6	Flame Scanner- Infrared
7	Pressure Control - Operating Limit
8	Pressure Control - High Limit (Manual Reset)
9	Pressure Control - Modulating
10	Main Low Water Column - Levelmaster II
11	Auxiliary Low Water Cutoff - Warrick 3C-2
12	Steam Gauge
13	N/A
14	Stack Thermometer
15	Safety Valve (3) Set @ 150#
16	Gas Train
17	Fuel Oil Piping Terminal
18	Fuel Oil Pump Assembly
19	Manway 12" x 16"
20	N/A

SERVICE CONNECTIONS	
A	Electric - Main Power Supply- 460 / 3 / 60
B	N/A
C	Exhaust Vent Pipe - 24" OD
D	Vent Flange (See Detail)
E	Steam Outlet - 8" 300# R.F. Flange
F	N/A
G	N/A
H	Feedwater - (2) 2.5 NPT
I	Bottom Blowdown - (2) 2.0 NPT
J	Water Column Blowdown - 0.75 NPT
K	Gauge Glass Blowdown - 0.25 NPT
L	Surface Blowoff - 1.0 NPT (with Collector Pipe)
M	N/A
N	Main Gas - 3.0 NPT
O	Minimum Inlet Gas Pressure Required is 105" w.c. Maximum Inlet Gas Pressure Required PSI: TBD Rating - 32,656 (cfh) MBtu
P	Oil Inlet - 0.75 NPT (75 PSI Required at Inlet) Rating - 233.3 gph
Q	Oil Outlet - 0.75 NPT
R	Chemical Feed - 1.0 NPT
S	Safety Valve - (2) Kunkle 6010JHE 2.0 x 2.5 FPT (Outlet)
T	Safety Valve - (1) Kunkle 6010HGE 1.5 x 2.0 FPT (Outlet)

NOTES

- * Boiler is Designed and Constructed in Accordance with the ASME Boiler and Pressure Vessel Code - Section 1 High Pressure Boiler
- * This Unit Complies with Insurance Underwriters Requirement for None Specified
- * The Boiler Package is painted with High Temperature Light Blue Enamel
- * The Burner Operation is Full Modulating
- * The Boiler Burner Package Has A UL Label

This Boiler Is Provided with:

- Control Circuit Transformer
- Welded End Caps on Baseraills

BOILER SPECIFICATIONS	
Boiler Designation - CBEX ELITE 200 800	
Design Pressure - 150 ST	
Design Rating - 800 hp	
Emissions - 60 ppm	
Fuel(s) - No. 2 Oil and Natural Gas	
Steam Capacity - 27,600# stim/hr @212 deg F	
Fireside Heating Surface - 2,301 Sq. Ft.	
Dry Weight - 40,840 LB	
Normal Water Weight - 25,870 LB	
Gallons (Operating) - 3,102	
Code Compliance -N/A	

THIS DRAWING IS PROPERTY OF CLEAVER-BROOKS DIVISION. IT IS SUBJECT TO CHANGE WITHOUT NOTICE, AND IS NOT TO BE COPIED OR USED IN ANY WAY DETRIMENTAL TO THE COMPANY.

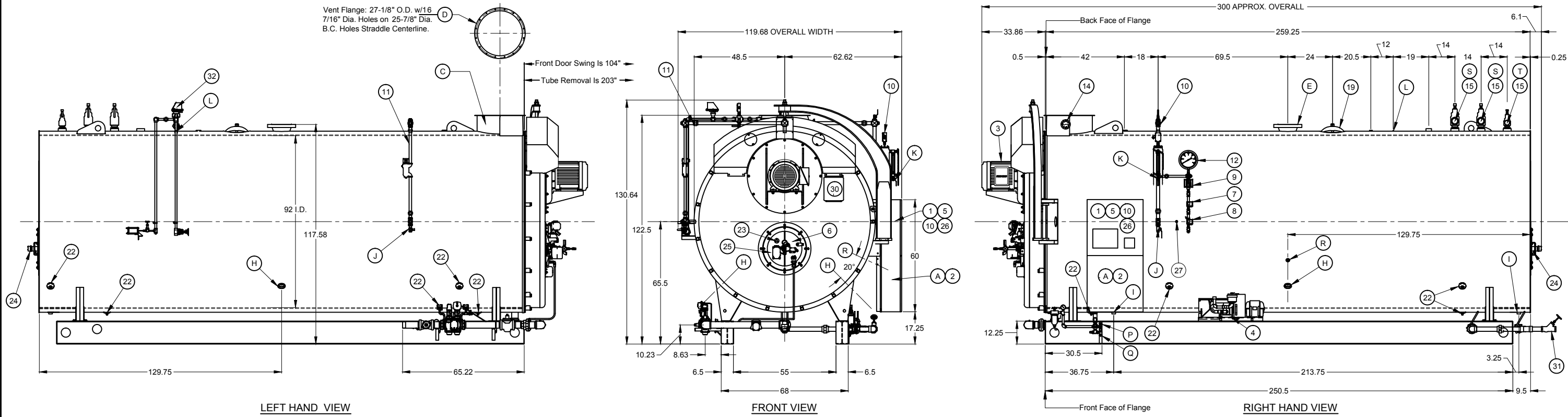

REVISIONS	DATE	BY	DESCRIPTION
00			

CAUTION

DIMENSIONS SHOWN ARE APPROXIMATE AND SHOULD NOT BE USED IN RESTRICTIVE LAYOUTS OR TO PREFABRICATE ASSEMBLIES UNLESS CLEAVER-BROOKS HAS BEEN CONSULTED. IT IS STRONGLY RECOMMENDED THAT THE CUSTOMER REQUEST AS-BUILT CERTIFIED DRAWINGS FOR THESE CASES.

WARNING

LIFTING LUGS PROVIDED ON THE VESSEL SHALL ONLY BE USED TO LIFT THE VESSEL WHEN IT IS DRY.

WARNING

CHANGES, MODIFICATIONS OR ALTERATIONS ARE STRICTLY PROHIBITED.

CHANGES TO THIS DRAWING AND SUBSEQUENT MODIFICATION OF EQUIPMENT COULD RESULT IN DAMAGE TO THE EQUIPMENT AND/OR SERIOUS PERSONAL INJURY.

PRELIMINARY

PRELIMINARY DIMENSIONAL DIAGRAM

SIZE D

SHT 01 OF 02

SCALE N.T.S.	DATE 12/21/11	CleaverBrooks	
DRAWN H L J	CHEKED BY M S T	MODEL 460	FUEL 3
		SIZE 60	PRESSURE 3
		CAPACITY N/A	INSURANCE N/A
DRWG. NO.		CBEX ELITE 800 HP 150	