

MAJOR COMPONENTS		SERVICE CONNECTIONS		NOTES
1	Control Panel	21	N/A	* Boiler is Designed and Constructed in Accordance with the ASME Boiler and Pressure Vessel Code - Section I High Pressure Boiler * This Unit Complies with Insurance Underwriters Requirement for Factory Mutual & GE Global Asset Protection * The Boiler Package is painted with High Temperature Light Blue Enamel * The Burner Operation is Full Modulating * The Boiler Burner Package Has a UL Label * All Valves to be Mounted, Hydro Tested, & Listed on All Applicable Forms This Boiler is Provided with: 1. Control Circuit Transformer 2. Welded End Caps on Baseballs
2	Entrance Panel	22	N/A	
3	Blower Motor - 75 HP	23	Front Sight Port	
4	Air Compressor - 15 HP	24	Rear Sight Port	
5	Combustion Safeguard Control - CB-760E	25	Burner	
6	Flame Scanner - Infrared	26	Alarm	
7	Pressure Control - Operating Limit	27	Low Fire Hold Control	
8	Pressure Control - High Limit (Manual Reset)	28	N/A	
9	Pressure Control - Modulating	29	N/A	
10	Main Low Water Column - Levelmaster II	30	N/A	
11	Auxiliary Low Water Cutoff - Warrtck 3C-2	31	Bottom Blowdown Piping	
12	Steam Gauge	32	Surface Blowdown Piping	
13	N/A	33	N/A	
14	Stack Thermometer	34	N/A	
15	Safety Valve (3) Set @ 150#	35	FGR Duct	
16	Gas Train	36	N/A	
17	Fuel Oil Piping Terminal	37	N/A	
18	Fuel Oil Pump Assembly	38	N/A	
19	Manway 12" x 16"	39	N/A	
20	Burner Junction Box	40	N/A	
		A	Electric - Main Power Supply - 460 / 3 / 60	
		B	N/A	
		C	Exhaust Vent Pipe - 32" OD	
		D	Vent Flange (See Detail)	
		E	Steam Outlet - 10" 300# R.F. Flange	
		F	N/A	
		G	N/A	
		H	Feedwater - (2) 3.0 NPT	
		I	Bottom Blowdown - (2) 2.0 NPT	
		J	Water Column Blowdown - 0.75 NPT	
		K	Gauge Glass Blowdown - 0.25 NPT	
		L	Surface Blowoff - 1.0 NPT (With Collector Pipe)	
		M	N/A	
		N	Main Gas - TBD	
		O	Minimum Inlet Gas Pressure Required: 50" W.C. Maximum Inlet Gas Pressure Required: TBD Rating - TBD (cfh) MBtu	
		P	Oil Inlet - 0.75 NPT (75 PSI Required at Inlet)	
		Q	Oil Outlet - 0.75 NPT	
		R	Chemical Feed - 1.0 NPT	
		S	Safety Valve - (3) Kunkle 6010JHE 2.0 x 2.5 FPT (Outlet)	
BOILER SPECIFICATIONS				
Boiler Designation - CBEX-P 200 900				
Design Pressure - 150 ST				
Design Rating - 900 hp				
Emissions - 30 ppm				
Fuel(s) - No. 2 Oil & Natural Gas				
Steam Capacity - 31,050B sm/hr @212 deg F				
FireSide Heating Surface - 2,810 Sq. Ft.				
Dry Weight - 47,000 LB				
Water Weight - 34,430 LB				
Gallons (Operating) - 4128				
Code Compliance - FM, GE Gap, NFPA-85, Former IRI				

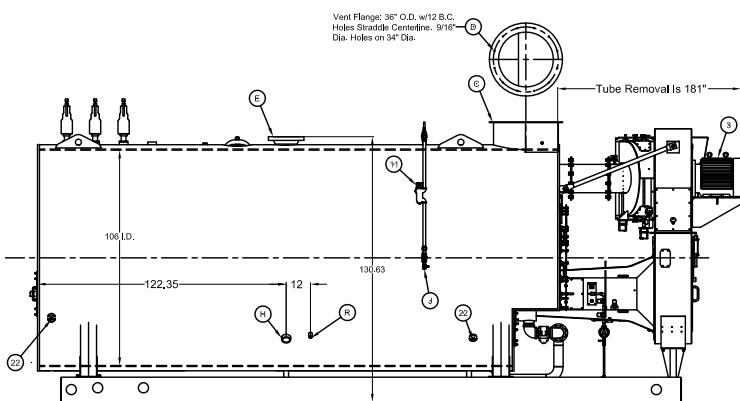

LEFT HAND VIEW

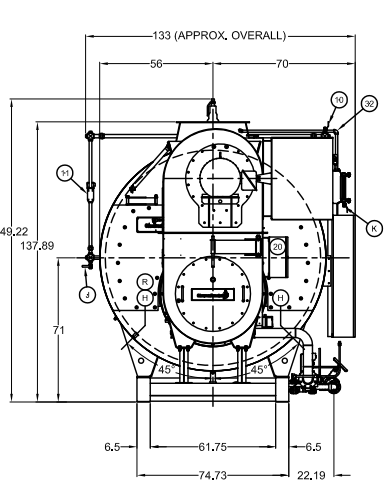

FRONT VIEW

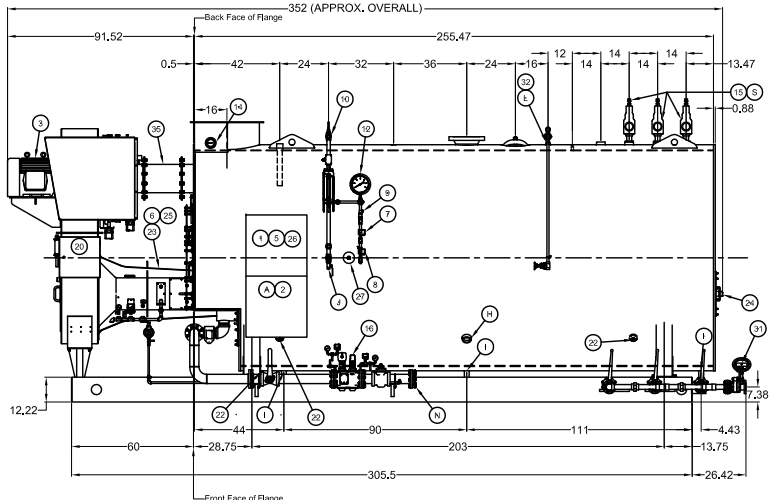

RIGHT HAND VIEW

THIS DRAWING IS PROPERTY OF CLEAVER-BROOKS DIVISION. IT IS SUBJECT TO CHANGE WITHOUT NOTICE, AND IS NOT TO BE COPIED OR USED IN ANY WAY DETRIMENTAL TO THE COMPANY.

REVISIONS

CAUTION

DIMENSIONS SHOWN ARE APPROXIMATE AND SHOULD NOT BE USED IN RESTRICTIVE LAYOUTS OR TO PREFABRICATE ASSEMBLIES UNLESS CLEAVER-BROOKS HAS BEEN CONSULTED. IT IS STRONGLY RECOMMENDED THAT THE CUSTOMER REQUEST AS-BUILT CERTIFIED DRAWINGS FOR THESE CASES.

WARNING

LIFTING LUGS PROVIDED ON THE VESSEL SHALL ONLY BE USED TO LIFT THE VESSEL WHEN IT IS DRY.

WARNING

CHANGES, MODIFICATIONS OR ALTERATIONS ARE STRICTLY PROHIBITED. CHANGES TO THIS DRAWING AND SUBSEQUENT MODIFICATION OF EQUIPMENT COULD RESULT IN DAMAGE TO THE EQUIPMENT AND/OR SERIOUS PERSONAL INJURY.

Name
Address

DIMENSIONAL DIAGRAM

SIZE: **D** SHT 01 OF 01

SCALE	N.T.S.
DATE	
DRAWN	LES
CHECKED BY	DJM

CleaverBrooks

CBEX-P	200	900	150ST	CAPACITY
460	3	60	3	FM&GAP
INCHES	INCHES	INCHES	INCHES	PERFORMANCE

DRWG. NO. **00**