



Skid Solutions

Steam and Hydronic

Installation Guide



750-394
5/2018

 **WARNING**

DO NOT OPERATE, SERVICE, OR REPAIR THIS EQUIPMENT BEFORE FULLY UNDERSTANDING THIS DOCUMENT AND ALL APPLICABLE USER MANUALS.

DO NOT ALLOW OTHERS TO OPERATE, SERVICE, OR REPAIR THIS EQUIPMENT UNLESS THEY FULLY UNDERSTAND ALL APPLICABLE USER DOCUMENTATION.

FAILURE TO FOLLOW WARNINGS AND INSTRUCTIONS MAY RESULT IN SEVERE PERSONAL INJURY OR DEATH.

It is recommended that a boiler room log or record be maintained. Recording of daily, weekly, monthly and yearly maintenance activities and recording of any unusual operation will serve as a valuable guide to any necessary investigation.

The operation of this equipment must comply with all requirements or regulations of the insurance company and/or other authority having jurisdiction. In the event of any conflict or inconsistency between such requirements and the warnings or instructions contained herein, please contact Cleaver-Brooks before proceeding.

Section 1 - Introduction

Cleaver-Brooks skid systems can combine one or more boilers with various ancillary components in a pre-engineered skid-mounted package. Many options are available - the following instructions apply to general system preparation, and will help to ensure trouble free startup and operation for all skid systems. Use this document in conjunction with the Cleaver-Brooks operation manuals for specific skid components. Each major skid component includes one copy of the respective Operation and Maintenance manual. Contact C-B for additional copies.

Boiler(s) and accessory skids ship as separate modules for ease of shipping and handling. Skids can be moved into position using a suitable fork lift, then fastened together or aligned using the bridge pieces or alignment equipment provided.

Immediately upon delivery, inspect the shipment for damage and ensure all required parts are present. Make sure all required job-specific documents are on hand, including wiring diagrams, dimensional/mechanical drawings, and piping diagrams. Report any damage or missing components to the C-B representative.

- Skids are available with single connection points for all major utilities and electrical power (common headers available for multiple boiler skids).

ATTENTION

Operation and maintenance manuals are provided separately for all major skid components. Users should become familiar with all documentation before starting or operating the equipment.



Section 2 - Equipment Mounting

Use the fork pockets (see **Figure 1**) and a suitable fork lift to transport and position each skid. If overhead rigging is necessary, contact Cleaver-Brooks.

Figure 1 - Fork Lift Pockets

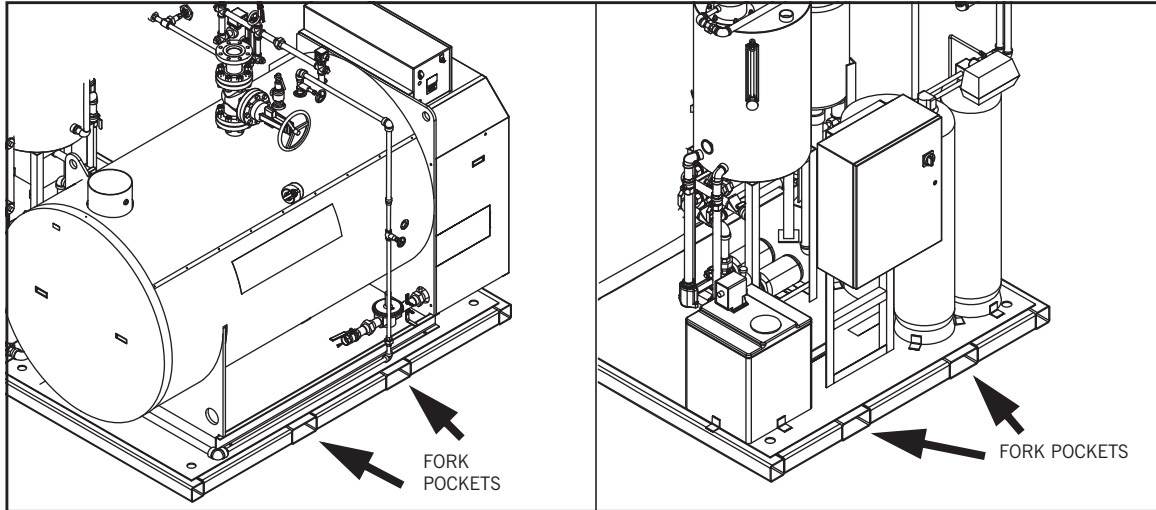

- **Skids must be installed on a suitable level surface.**
- Arrange the skids according to drawings provided for the installation. Skids are factory match-marked to show correct orientation and must be assembled in the proper position. *Multiple boiler skids are not interchangeable; observe the original factory arrangement when making connections.*
- Fasten the skids together using the supplied bridge connectors and/or mounting hardware.
- To facilitate piping connections, ensure all skids are level (front-to-back, side-to-side, and corner-to-corner) before connecting.
- Observe equipment clearances when installing; refer to dimension diagrams and clearance information provided. Skid orientation should permit access to all operator controls and should allow sufficient clearance for maintenance. Refer to local codes as applicable. Compliance with local codes is the responsibility of the installing contractor.
- If anchor tabs are provided, do not bolt skids to the floor or pad until all piping has been assembled and tightened.

Figure 2 - Bridge Connector

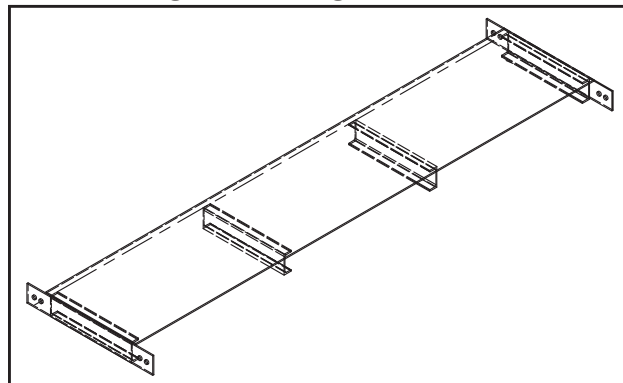

Section 3 - Piping Connections

3.1 Connections Between Skids

After assembling the skids it will be necessary to make connections between individual skid sections. Refer to C-B supplied mechanical drawings when making connections. All connections should be matched and properly aligned before tightening.

Piping connections between skids have been factory match-marked prior to disassembly for shipment. Observe match markings when reassembling interconnecting piping.

Refer to job specific drawings for complete installation scope.

NOTE: To ensure proper alignment of components, hand tighten until all connections are in place.

A visual inspection should be part of the final assembly process. Verify all piping has been correctly installed and all necessary clearances maintained.

Check all couplings for tightness (including factory connections, in case of loosening during shipment).

Perform a pneumatic leak test after final assembly. Specific leak test requirements may vary depending on the equipment installed. Ensure all interconnecting piping is free of leaks prior to filling system.

Reexamine connections after the first operating cycle. Some re-tightening may be necessary.

Figure 3 - Match Marks

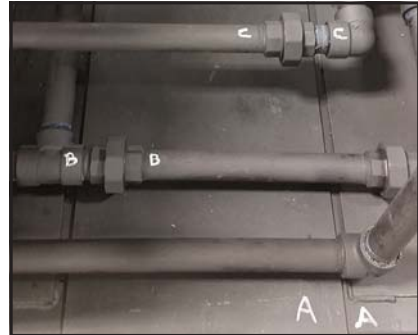

ATTENTION: Insulation of skid piping is recommended.

3.2 External Connections

Gas Supply Pipe Sizing - Refer to boiler manual. If a multiple boiler gas header is provided, refer to installation drawings and submittal documents for pressure and flow requirements.

Safety Relief Valve - Pipe to a point of safe discharge. Refer to boiler manual for further information.

Drain - The boiler and accessories are piped to a common drain. The drain should be piped to a suitable point of safe discharge.

System Makeup Water Connection - A single point makeup water connection is provided; install backflow prevention if required by local codes.

Miscellaneous - If the system includes ancillary equipment requiring venting to atmosphere (blow-down separators, feed systems, auto air vents, etc.), provisions should be made according to the individual product documentation and local code requirements.

Flue Gas Venting - Refer to boiler manual.

Combustion Air Inlet - Refer to boiler manual.

Section 4 - Controls and Electrical Connections



ATTENTION

Electrical supply must be of proper voltage and phase. Verify agreement between:

- Submittal documents
- Electrical nameplate
- Supply power

Verify factory wiring connections are secure.

No additional wire should be necessary for making wiring connections between skids. Route through the conduits provided. Wires are color coded and a junction box is installed on each skid. Refer to job specific wiring diagrams.

For most installations there will be a single point electrical connection on the accessory skid. Power transformers are provided for all equipment operating at non-supply voltage.

Ship loose components will require field mounting and wiring.

Electrical connections must comply with code requirements and must be arranged so that all components remain accessible for inspection, cleaning, or maintenance.

Ensure proper clearance of electrical panels to comply with local code requirements.

Check pump rotation if applicable. Correct rotation is indicated on the pump motor casing. Refer to pump manual if direction of rotation is incorrect.

Ensure control/communication wiring is isolated from power and high voltage wiring.

REFER TO FACTORY WIRING DIAGRAMS for individual components and for overall skid wiring.

Figure 4 - Skid Wiring

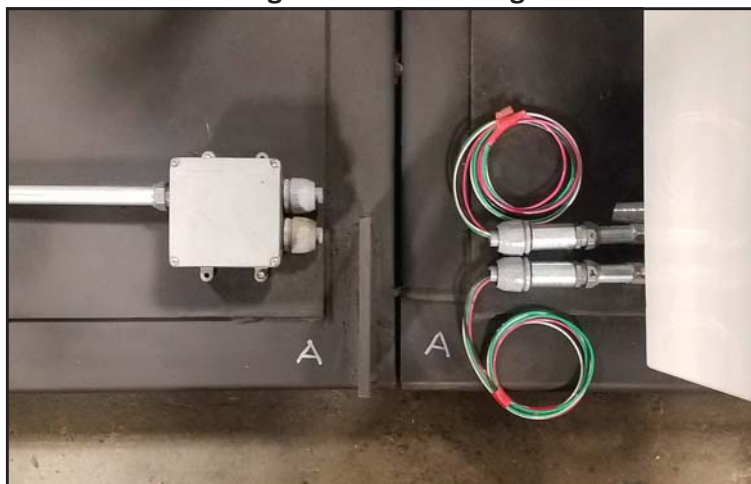

Section 5 - Installation Checklist

The following checklist is provided to help ensure the system is ready for initial startup. Prior to requesting a scheduled startup from your local Cleaver-Brooks authorized service representative, all items on the list should be checked off. Failure to do so may result in startup delays. A copy of this checklist may be sent to the startup representative for record keeping and scheduling use.

A. GENERAL

Yes	No	
_____	_____	1. Is the boiler, including burner, trim and controls, in good operating condition? If not, note items that require attention:
_____	_____	2. Is the burner fuel and pilot supply properly installed according to manual?
_____	_____	3. If dual fuel, are both fuels available for start-up?
_____	_____	4. Are the skids level?
_____	_____	5. Where required, will qualified boiler operators be present for start-up?
_____	_____	6. Will operating personnel be available for training during start-up?
_____	_____	7. Will a person be available if needed to assist the service technician with miscellaneous tasks in the boiler room?
_____	_____	8. Have all skid piping connections been completed?
_____	_____	9. A full capacity load (sufficient for high fire fuel/air ratio adjustment) will be required for complete burner adjustment. Can this load be absorbed by the system, and have provisions been made to put a full load on the boiler during start-up?
_____	_____	10. Is all accessory equipment properly vented according to equipment manuals?

B. BOILER

Yes	No	
_____	_____	1. Is the boiler, burner, and auxiliary equipment installed in accordance with the manufacturer's and insurer's requirements, and applicable insurance and regulatory codes?
_____	_____	2. Is the safety relief valve (s) properly installed?
_____	_____	3. Is the safety relief valve (s) discharge piping properly installed with no weight or strain on the valve (s)?
_____	_____	4. Are relief valves piped to a safe discharge, and are the drain lines installed in accordance with all applicable regulatory codes?
_____	_____	5. Is the return water temperature thermometer installed in the system return fitting? [Applicable to hot water units only].
_____	_____	6. Has the boiler air vent been properly piped or an auto air vent device supplied to eliminate air entrapment? [Applicable to hot water units only].
_____	_____	7. If supplied, has the stack thermometer been installed?
_____	_____	8. Has the breeching/stack been properly installed?
_____	_____	9. Has the source of combustion air been verified and properly sized?
_____	_____	10. Have all shipped loose items been accounted for and installed?

Installation Checklist

C. ELECTRICAL

- | Yes | No | |
|-------|-------|--|
| _____ | _____ | 1. Is the available power supply (voltage, phase, and hertz) correct per the skid panel data plate and wiring diagram information? |
| _____ | _____ | 2. Have all electrical connections been made for the boiler, burner, and all auxiliary equipment? |
| _____ | _____ | 3. Have emergency and safety devices been installed in accordance with regulatory codes? |
| _____ | _____ | 4. Have all boiler field-wired connections been made according to the wiring diagram supplied by Cleaver-Brooks for the particular installation? |
| _____ | _____ | 5. Is the equipment properly grounded to earth ground? |

D. WATER

- | Yes | No | |
|-------|-------|--|
| _____ | _____ | 1. Has the make-up water system and pressure regulating valve been connected and are they operable? |
| _____ | _____ | 2. Has the boiler and system been filled with properly treated water at a minimum of 70 degrees Fahrenheit (21.1 Celsius)? |
| _____ | _____ | 3. Have the boiler and system been pressure tested to check for leaks? |
| _____ | _____ | 4. Has the system piping been flushed and cleaned or will this be accomplished during start-up? |

E. FUEL

- | Yes | No | |
|-------|-------|--|
| _____ | _____ | 1. Have all fuel lines been pressure tested according to local codes, then purged of air? |
| _____ | _____ | 2. Is fuel pressure and volume sufficient for the boiler (s) at maximum firing rate as stated on the nameplate? |
| _____ | _____ | 3. Are gas pressure gauges installed and are they indicating proper gas pressure upstream of the boiler mounted gas regulator? |
| _____ | _____ | 4. Are gas vents including vent valves, properly piped to a point of safe discharge? |
| _____ | _____ | 5. Has insurance inspection, if required, been completed? |
| _____ | _____ | 6. If upstream gas pressure exceeds 5 psig (34.5 kpa), have gas pressure relief valves been installed? |

