

MAJOR COMPONENTS		SERVICE CONNECTIONS		NOTES
1	Control Panel	21	N/A	* Boiler Is Designed and Constructed In Accordance with the ASME Boiler and Pressure Vessel Code - Section I High Pressure Boiler * This Unit Complies with Insurance Underwriters Requirement for Factory Mutual & GE Global Asset Protection * The Boiler Package is painted with High Temperature Light Blue Enamel * The Burner Operation Is Full Modulating * The Boiler Burner Package Has a UL Label * All Valves to be Mounted, Hydro Tested, & Listed on All Applicable Forms This Boiler Is Provided with: 1. Control Circuit Transformer 2. Welded End Caps on Basesalls
2	Entrance Panel	22	N/A	
3	Blower Motor - 30 HP	23	Front Slight Port	
4	Air Compressor - 7.5 HP	24	Rear Slight Port	
5	Combustion Safeguard Control - CB-760E	25	Burner	
6	Flame Scanner - Infrared	26	Alarm	
7	Pressure Control - Operating Limit	27	Low Fire Hold Control	
8	Pressure Control - High Limit (Manual Reset)	28	N/A	
9	Pressure Control - Modulating	29	N/A	
10	Main Low Water Column - Levelmaster II	30	N/A	
11	Auxiliary Low Water Cutoff - Warrick 3C-2	31	Bottom Blowdown Piping	
12	Steam Gauge	32	Surface Blowdown Piping	
13	N/A	33	N/A	
14	Stack Thermometer	34	N/A	
15	Safety Valve (3) Set @ 150#	35	FGR Duct	
16	Gas Train	36	N/A	
17	Fuel Oil Piping Terminal	37	N/A	
18	Fuel Oil Pump Assembly	38	N/A	
19	Manway 12" x 16"	39	N/A	
20	Burner Junction Box	40	N/A	
A	Electric - Main Power Supply - 460 / 3 / 60			
B	N/A			
C	Exhaust Vent Pipe - 24" OD			
D	Vent Flange (See Detail)			
E	Steam Outlet - 6" 300# R.F. Flange			
F	N/A			
G	N/A			
H	Feedwater - (2) 2.5 NPT			
I	Bottom Blowdown - (2) 2.0 NPT			
J	Water Column Blowdown - 0.75 NPT			
K	Gauge Glass Blowdown - 0.25 NPT			
L	Surface Blowoff - 1.0 NPT (With Collector Pipe)			
M	N/A			
N	Main Gas - TBD			
O	Minimum Inlet Gas Pressure Required: 87" W.C. Maximum Inlet Gas Pressure Required Is TBD Rating - 29,288 MBtu			
P	Oil Inlet - 0.75 NPT (75 PSI Required at Inlet)			
Q	Oil Outlet - 0.75 NPT			
R	Chemical Feed - 1.0 NPT			
S	Safety Valve - (2) Kunkle 6010JHE 2.0 x 2.5 FPT (Outlet)			
T	Safety Valve - (1) Kunkle 6010JGE 1.5 x 2.0 FPT (Outlet)			

BOILER SPECIFICATIONS

Boiler Designation - CBEX-P 200 700
 Design Pressure - 150 ST
 Design Rating - 700
 Emissions - 30 ppm
 Fuel(s) - No. 2 Oil & Natural Gas
 Steam Capacity - 24,150# steam @ 212 deg F
 Fireside Heating Surface - 1,776 Sq. Ft.
 Dry Weight - 32,100 LB
 Water Weight - 20,000 LB
 Gallons (Operating) - 2,389
 Code Compliance - FM, GE Gap, NFPA-85, Former IRI

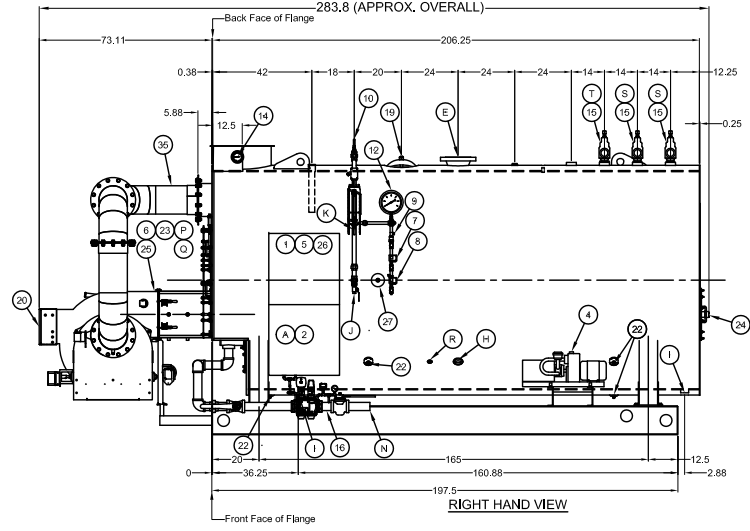
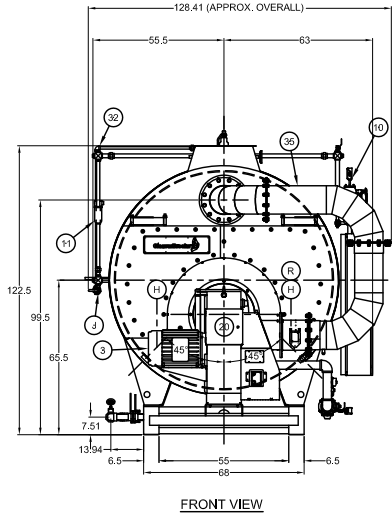
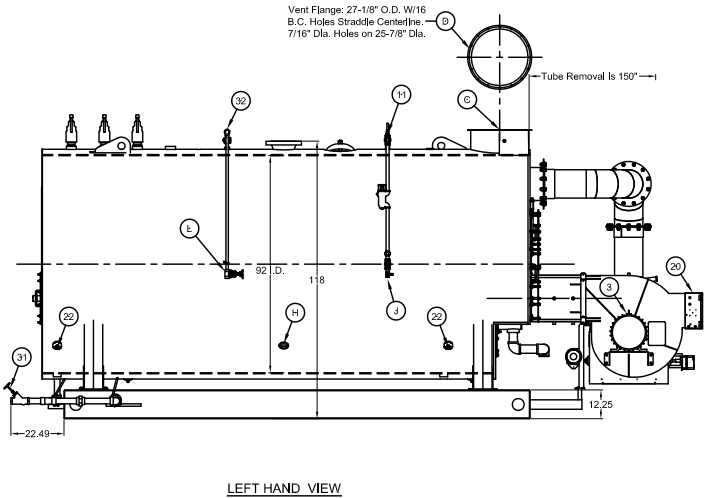

THIS DRAWING IS PROPERTY OF CLEAVER-BROOKS DIVISION. IT IS SUBJECT TO CHANGE WITHOUT NOTICE, AND IS NOT TO BE COPIED OR USED IN ANY MANNER DETRIMENTAL TO THE COMPANY.

REVISIONS	

CAUTION

DIMENSIONS SHOWN ARE APPROXIMATE AND SHOULD NOT BE USED IN RESTRICTIVE LAYOUTS OR TO PREFABRICATE ASSEMBLIES UNLESS CLEAVER-BROOKS HAS BEEN CONSULTED. IT IS STRONGLY RECOMMENDED THAT THE CUSTOMER REQUEST AS-BUILT CERTIFIED DRAWINGS FOR THESE CASES.

WARNING

LIFTING LUGS PROVIDED ON THE VESSEL SHALL ONLY BE USED TO LIFT THE VESSEL WHEN IT IS DRY.

WARNING

CHANGES, MODIFICATIONS OR ALTERATIONS ARE STRICTLY PROHIBITED.

CHANGES TO THIS DRAWING AND SUBSEQUENT MODIFICATION OF EQUIPMENT COULD RESULT IN DAMAGE TO THE EQUIPMENT AND/OR SERIOUS PERSONAL INJURY.

Name	Address
DIMENSIONAL DIAGRAM	
SIZE	SHT 01 OF 01

SCALE	N.T.S.	CleaverBrooks
DATE		
DRAWN	LES	CBEX-P 200 700 150ST CAPACITY 460 3 60 3 FM&GAP MODEL PRICE CODE WEL WEIGHT PRESSURE SERVICE
CHECKED BY	DJM	
DRWG. NO.		00