

THIS DRAWING IS A PRELIMINARY LAYOUT ONLY. ALL DIMENSIONS ARE TO BE FINALIZED AFTER FORMAL PURCHASE ORDER AND COMPLETE ENGINEERING APPROVAL. CLEAVER-BROOKS PROPOSAL

DO NOT SCALE - USE DIMENSIONS ONLY
 NF/BO - NOT FURNISHED BY CLEAVER-BROOKS
 DO NOT USE FOR CONSTRUCTION
 THIS DRAWING IS THE PROPERTY OF CLEAVER-BROOKS AND IS LOANED ON CONDITION THAT IT SHALL NOT BE COPIED OR REPRODUCED IN WHOLE OR IN PART OR DISCLOSED TO ANY THIRD PARTY OR USED IN ANY WAY WITHOUT THE WRITTEN CONSENT OF CLEAVER-BROOKS. ANY EQUIPMENT OR MATERIAL SHOWN, BUT NOT FURNISHED BY CLEAVER-BROOKS IS FOR ILLUSTRATING THE APPLICATION, AND CLEAVER-BROOKS ACCEPTS NO RESPONSIBILITY AS TO INSTALLATION OR OPERATION OF SUCH EQUIPMENT OR MATERIALS.

REV.	DATE	DESCRIPTION	DWN	CHK	APPR

NOTES:

1. DRAWING IS FOR OVERALL SIZE AND ARRANGEMENT ONLY. REFER TO PROPOSAL FOR ACTUAL TRIM LIST.
2. DRAWING IS NOT TO BE USED FOR CONSTRUCTION PURPOSES.
3. FEEDWATER SIZING AND LOCATIONS OF VALVES AND PIPING IS A REPRESENTATION ONLY, AND IS USED TO SHOW AN EASILY VISIBLE PICTORIAL VIEW.
4. * - DENOTES TO BE DETERMINED.

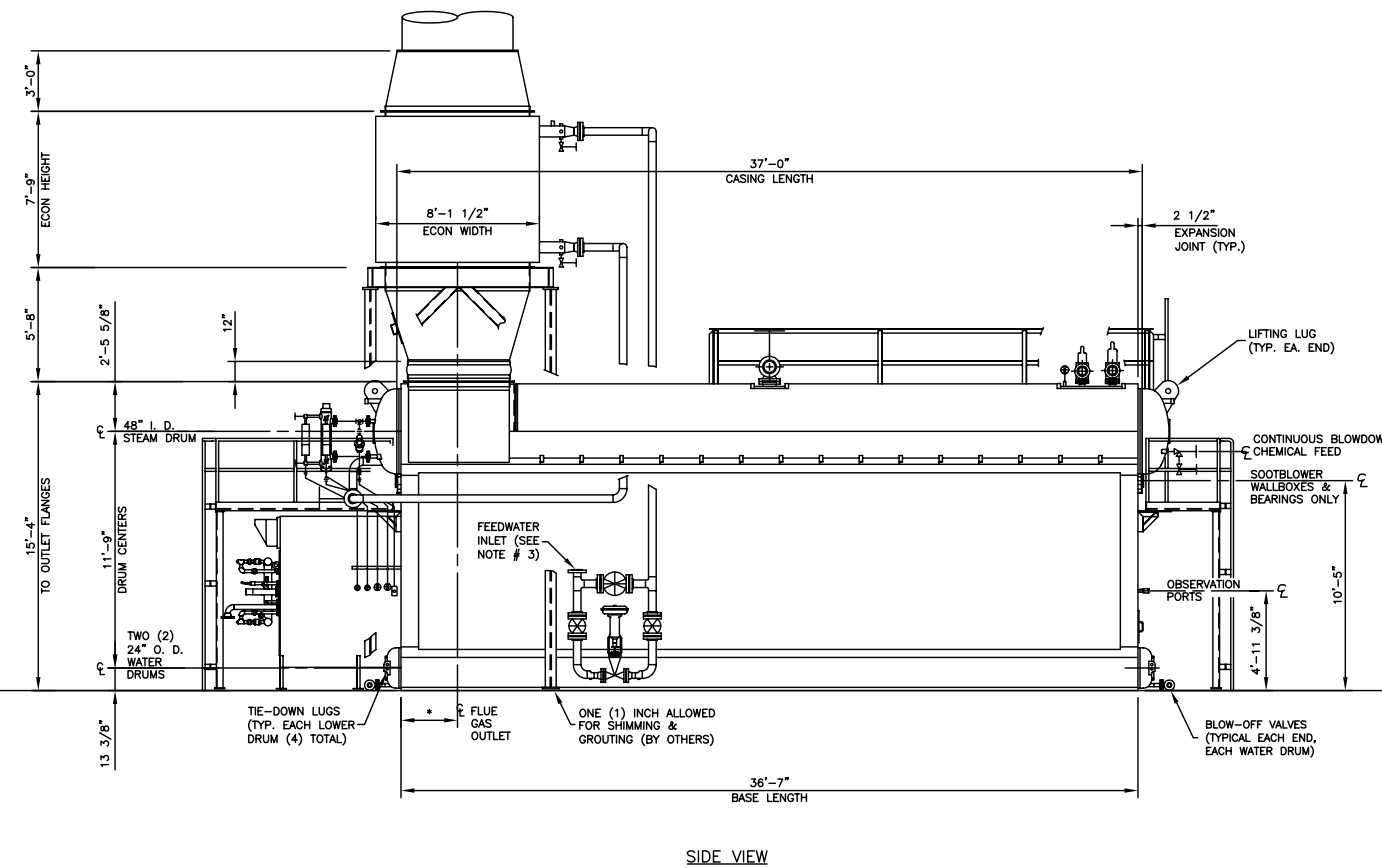
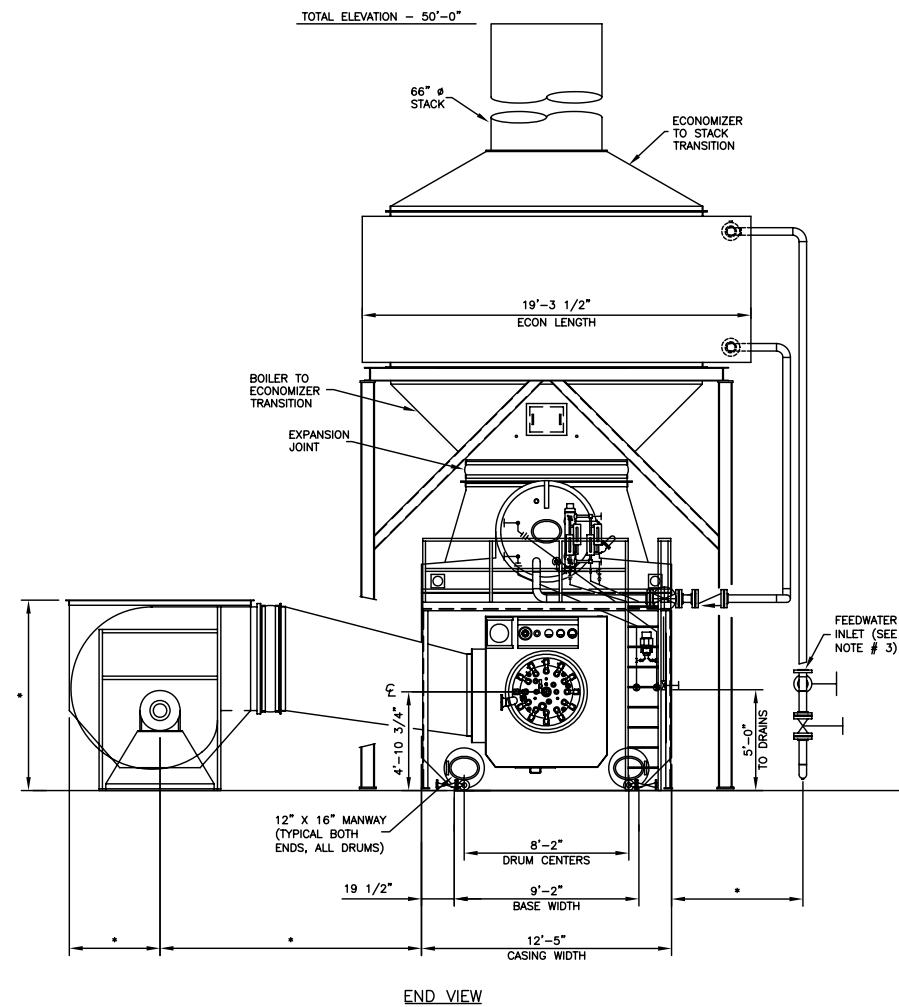
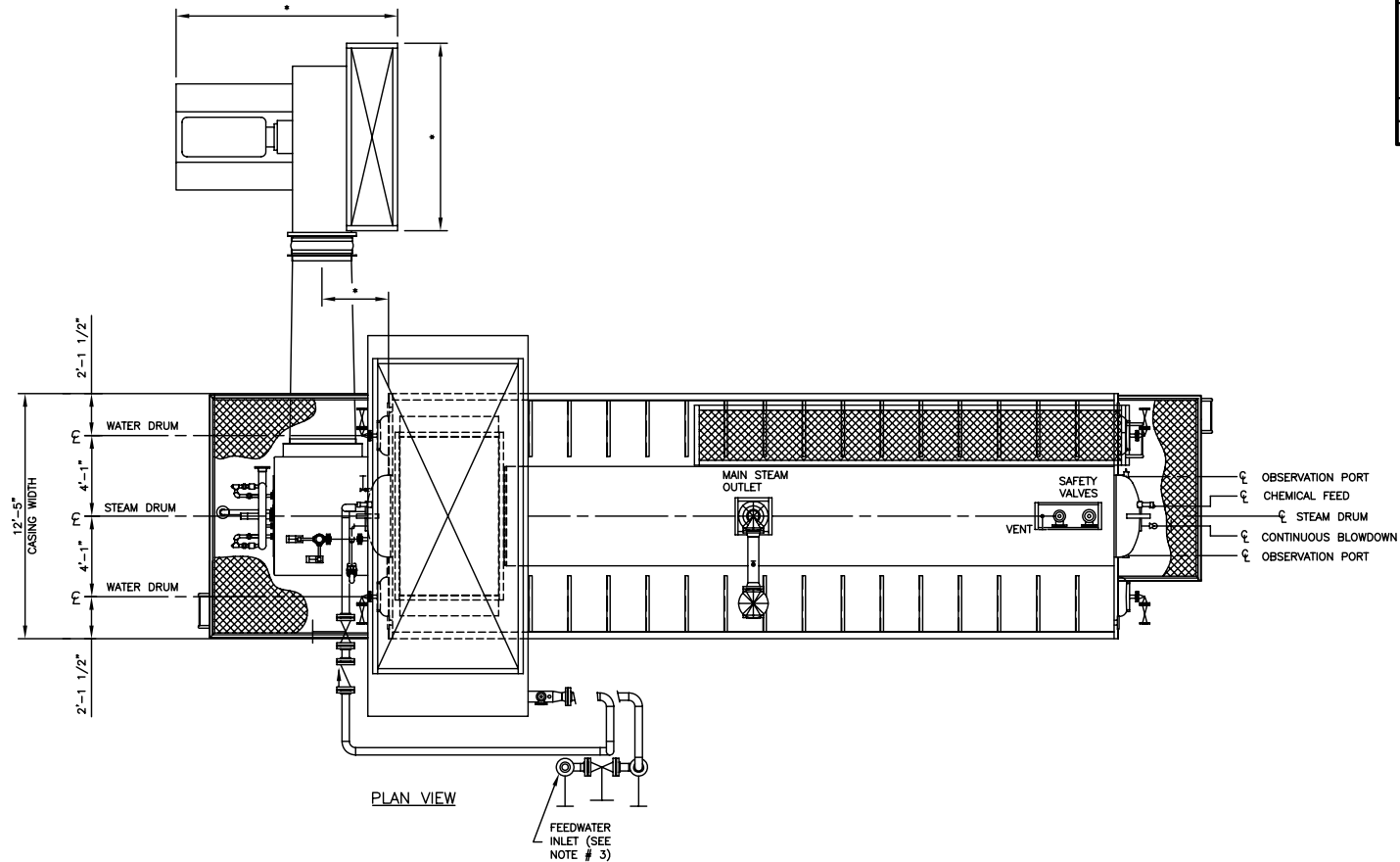

CleaverBrooks
 ENGINEERED BOILER SYSTEMS
 NEBRASKA BOILER, CLEAVER-BROOKS, AND ENERGY RECOVERY INTERNATIONAL
 WITH NATCOM BURNER SYSTEMS

GENERAL ARRANGEMENT SERIES:
 N2S-7/S-106 W/ECONOMIZER (HM-STD)

LAYOUT DRAWING FOR
 175,000 LB./HR. "A" BOILER

SCALE: NONE	DATE: APRIL 26, 2010
DRAWN BY: KENB	CHECKED:
JOB NO: PROPOSAL	PAGE NO: 1 OF 1
QTY:	DRAWING NO: N2S-7S-106 2010