

# Model **CBLE** Boilers

## Dimensions and Ratings 125-800 HP



**Table 1. Model CBLE Steam Boiler Ratings**

BOILER HP	125	150	200	250	300	350	400	500	600	700	800
RATINGS SEA LEVEL TO 700 FT											
Rated Steam Cap. (lbs/hr from and @ 212 °F)	4313	5175	6900	8625	10350	12075	13800	17250	20700	24150	27600
Btu Output (1000 Btu/hr)	4184	5021	6695	8369	10043	11716	13390	16738	20085	23433	26780
APPROXIMATE FUEL CONSUMPTION AT RATED CAPACITY											
Light Oil (gph) <sup>A</sup>	36.4	43.7	58.3	72.9	87.5	102.1	116.6	145.8	175.0	204.1	233.3
Natural Gas (cfh) MBTU	5103	6123	8165	10206	12247	14288	16329	20412	24494	28576	32659
Gas (Therm/hr)	51.0	61.2	81.66	102.1	122.5	142.9	163.3	204.1	244.9	285.8	326.6
POWER REQUIREMENTS - SEA LEVEL TO 700 FT, 60 HZ											
Blower Motor hp	Refer to Tables 9 and 10										
Oil Pump Motor, hp No. 2 Oil	1/2	1/2	1/2	1/2	3/4	3/4	3/4	3/4	3/4	1	1
Air Compressor Motor hp (Oil firing only)	3	3	3	3	5	5	5	7-1/2	7-1/2	7-1/2	7-1/2

NOTES:  
A. Based on 140,000 Btu/gal.

**Table 2. Model CBLE Hot Water Boiler Ratings**

BOILER HP	125	150	200	250	300	350	400	500	600	700	800
POWER REQUIREMENTS - SEA LEVEL TO 700 FT, 60 HZ											
Rated Cap. Btu Output (1000 Btu/hr)	4184	5021	6695	8369	10043	11716	13390	16738	20085	23433	26780
APPROXIMATE FUEL CONSUMPTION AT RATED CAPACITY											
Light Oil (gph) <sup>A</sup>	36.4	43.7	58.3	72.9	87.5	102.1	116.6	145.8	175.0	204.1	233.3
Natural Gas (cfh) MBTU	5103	6123	8165	10206	12247	14288	16329	20412	24494	28576	32659
Gas (Therm/hr)	51.0	61.2	81.6	102.1	122.5	142.9	163.3	204.1	244.9	285.8	326.6
POWER REQUIREMENTS - SEA LEVEL TO 700 FT, 60 HZ											
Blower Motor hp	Refer to Tables 9 and 10										
Oil Pump Motor, hp No. 2 Oil	1/2	1/2	1/2	1/2	3/4	3/4	3/4	3/4	3/4	1	1
Air Compressor Motor hp (Oil firing only)	3	3	3	5	5	5	7-1/2	7-1/2	7-1/2	7-1/2	7-1/2

NOTES:  
A. Based on 140,000 Btu/gal.

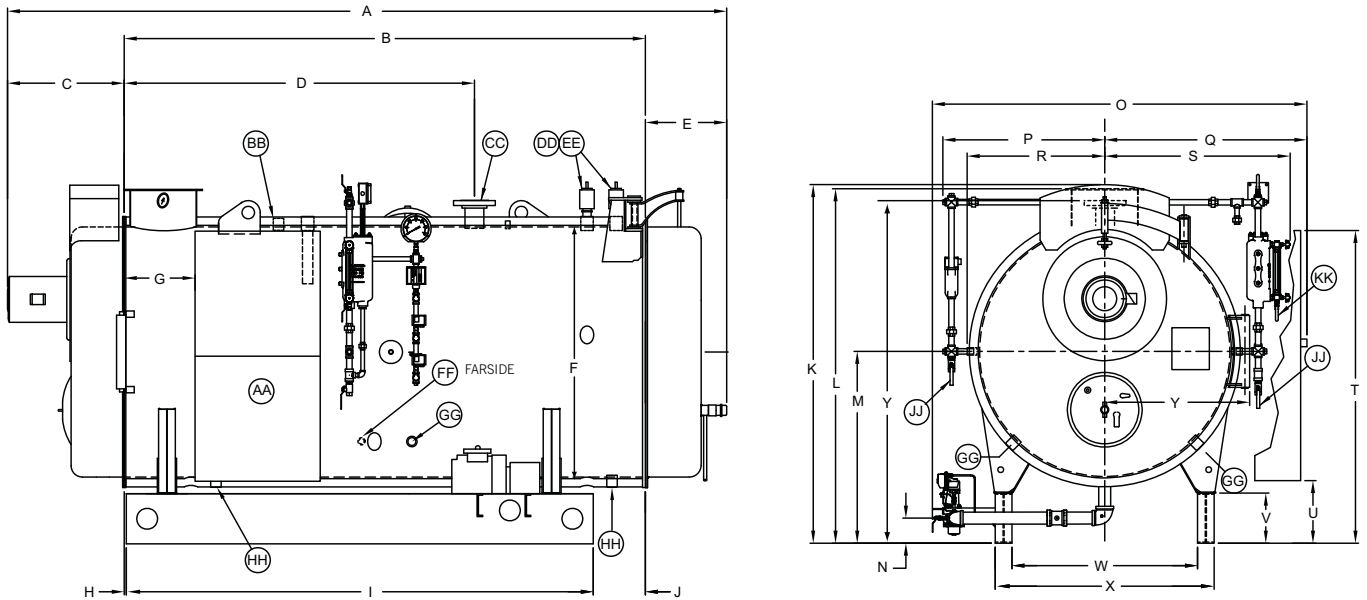
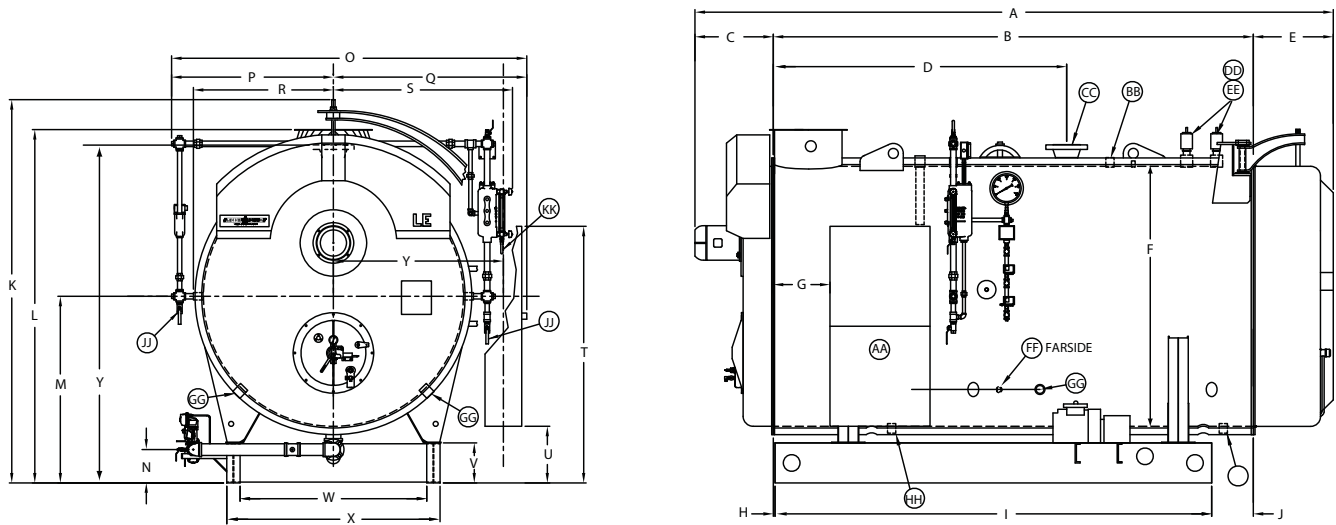

**Table 3. Model CBLE Steam Boiler Dimensions, 60" (15 - 150 psig Design Pressure)**

Description	DIM	Boiler HP		
		125	150	200
<b>LENGTHS</b>				
Length Overall	A	173	196.5	228.5
Shell	B	125	149	180
Front Head Extension	C	28	28	29
Front Ring Flange to Nozzle - 15#	D	88	90	96
Front Ring Flange to Nozzle - 150#	D	84	84	96
Rear Head Extension	E	19.5	19.5	19.5
Front Ring Flange to Panel	G	17	17	17
Ring Flange to Base	H	0.5	0.5	0.5
Base Frame	I	112	136	167
Rear Flange Ring to Base	J	12.5	12.5	12.5
<b>HEIGHTS</b>				
Ht Overall	K	87	87	87
Base to Vent Outlet	L	87	87	87
Base to Boiler Centerline	M	46	46	46
Base to Gas Train	N	6	8.5	8.5
Base to Panel Top	T	75	75	77
Base to Panel Bottom	U	15	15	17
Height of Base	V	12	12	12
Base to Steam Nozzle	Y	82.38	82.38	82.38
<b>WIDTHS</b>				
Width Overall	O	89.88	89.875	90.5
Center to ALWCO	P	38.75	38.75	38.75
Center to Outside Control Panel	Q	48.5	48.5	48.5
Center to Lagging	R	33	33	33
Center to WC	S	44.5	45	45
Base Inside	W	44.5	44.5	44.5
Base Outside	X	52.5	52.5	52.5
Boiler I.D.	F	60	60	60
<b>CONNECTIONS</b>				

**Table 3. Model CBLE Steam Boiler Dimensions, 60" (15 - 150 psig Design Pressure) (Continued)**

Description	DIM	Boiler HP		
		125	150	200
Electric - Main Power Supply	AA	460 / 3 / 60	460 / 3 / 60	460 / 3 / 60
Surface Blowoff (with collector pipe)	BB	1	1	1
Steam Outlet 15# (150# Flange)	CC	8	8	10
Steam Outlet 150# (300# Flange)	CC	4	4	4
Chemical Feed	FF	1	1	1
Feed Water (2)	GG	1.5	1.5	2
Blowdown/Drain (2)	HH	1.5	1.5	1.5
Water Column Blowdown	JJ	0.75	0.75	0.75
Gauge Glass Blowdown	KK	.025	0.25	0.25
<b>VENT STACK</b>				
Diameter (OD) (flgd. connection)		16	16	16
<b>CLEARANCES</b>				
Rear Door Swing (Davited)		32	32	32
Front Door Swing		67	67	67
Tube Removal, Rear		115	139	170
Tube Removal, Front		103	127	158
<b>MINIMUM BOILER ROOM LENGTH ALLOWING FOR DOOR SWING AND TUBE REMOVAL:</b>				
From Rear of Boiler		307	355	417
From Front of Boiler		260	308	370
Through Window or Doorway		224	248	279
<b>WEIGHT IN LBS</b>				
Normal Water Capacity		5750	7250	8625
Approx. Ship Wt. 15 psig		11300	12600	14600
Approx. Ship Wt. 150 psig		12400	13500	15600
Approx. Ship Wt. 200 psig		13000	14200	16400

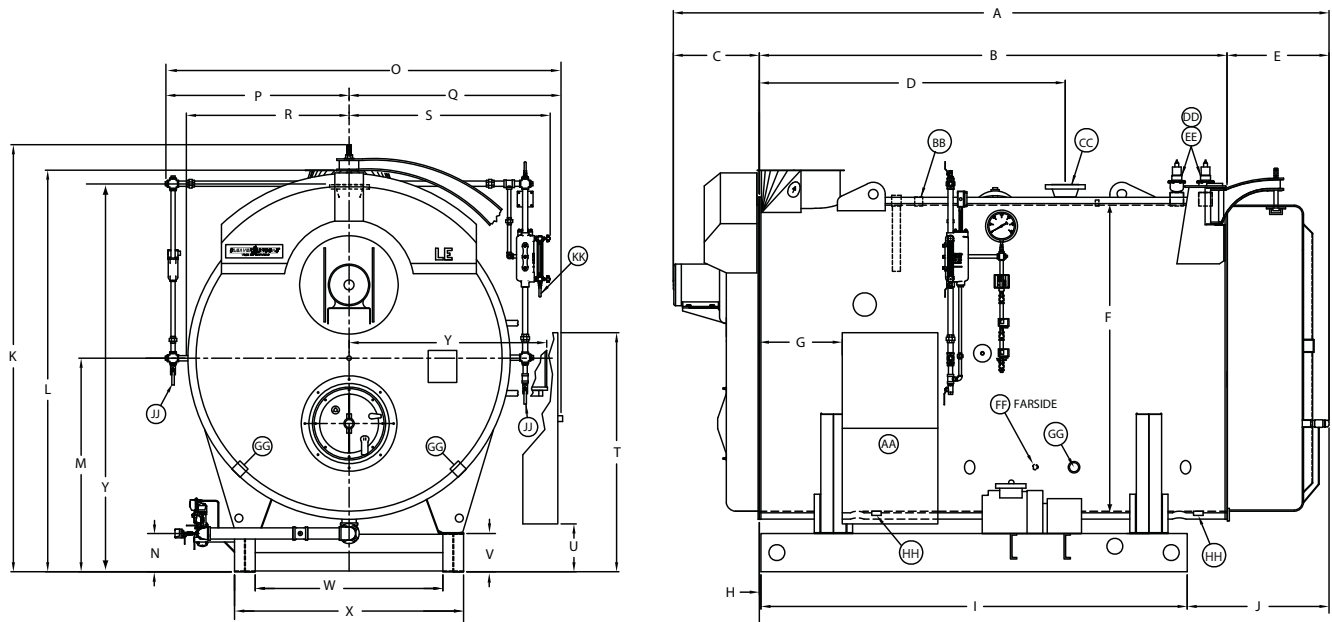

**Table 4. Model CBLE Steam Boiler Dimensions, 78" (15 - 150 psig Design Pressure)**

Description	DIM	Boiler HP		
		250	300	350
<b>LENGTHS</b>				
Length Overall	A	191.5	220	250
Shell	B	144	171	201
Front Head Extension	C	23.5	25	25
Front Ring Flange to Nozzle - 15#	D	90	98	112
Front Ring Flange to Nozzle - 150#	D	88	98	112
Rear Head Extension	E	24	24	24
Front Ring Flange to Panel	G	17	23	23
Ring Flange to Base	H	0.5	0.5	0.5
Base Frame	I	131	158	188
Rear Flange Ring to Base	J	12.5	12.5	12.5
<b>HEIGHTS</b>				
Ht Overall	K	115	115	115
Base to Vent Outlet	L	106	106	106
Base to Boiler Centerline	M	56	56	56
Base to Gas Train	N	10	10	10
Base to Panel Top	T	77	77	77
Base to Panel Bottom	U	17	17	17
Height of Base	V	12	12	12
Base to Steam Nozzle	Y	101.50	101.50	101.50
<b>WIDTHS</b>				
Width Overall	O	106.5	106.5	108.75
Center to ALWCO	P	48.5	48.5	48.5
Center to Outside Control Panel	Q	58	58	58
Center to Lagging	R	42	42	42
Center to WC	S	53.75	53.75	53.75
Base Inside	W	56	56	56
Base Outside	X	64	64	64
Boiler I.D.	F	78	78	78
<b>CONNECTIONS</b>				
Electric - Main Power Supply	AA	460 / 3 / 60	460 / 3 / 60	460 / 3 / 60
Surface Blowoff (with collector pipe)	BB	1	1	1
Steam Outlet 15# (150# Flange)	CC	10	12	12

**Table 4. Model CBLE Steam Boiler Dimensions, 78" (15 - 150 psig Design Pressure) (Continued)**

Description	DIM	Boiler HP		
		250	300	350
Steam Outlet 150# (300# Flange)	CC	6	6	6
Chemical Feed	FF	1	1	1
Feed Water (2)	GG	2	2	2.5
Blowdown/Drain (2)	HH	1.5	1.5	1.5
Water Column Blowdown	JJ	0.75	0.75	0.75
Gauge Glass Blowdown	KK	0.25	0.25	0.25
VENT STACK				
Diameter (OD) (flgd. connection)		20	20	20
CLEARANCES				
Rear Door Swing		43	43	43
Front Door Swing		89	89	89
Tube Removal, Rear		131	157	187
Tube Removal, Front		116	142	172
MINIMUM BOILER ROOM LENGTH ALLOWING FOR DOOR SWING AND TUBE REMOVAL				
From Rear of Boiler		364	417	477
From Front of Boiler		303	356	416
Through Window or Doorway		275	302	332
WEIGHT IN LBS				
Normal Water Capacity		10670	13000	15465
Approx. Ship Wt. 15 psig		21500	23600	26800
Approx. Ship Wt. 150 psig		22800	25200	27800
Approx. Ship Wt. 200 psig		24600	27200	29300



**Table 5. Model CBLE Steam Boiler Dimensions, 96" (15 - 150 psig design pressure)**

Description	DIM	Boiler HP				
		400	500	600	700	800
<b>LENGTHS</b>						
Length Overall	A	205.75	227.75	259.75	298.75	298.75
Shell	B	146.75	167.5	199.75	232.75	232.75
Front Head Extension	C	27	28	28	34	34
Front Ring Flange to Nozzle - 15#	D	98	101	96	112	112
Front Ring Flange to Nozzle - 150#	D	96	100	96	112	112
Rear Head Extension	E	32	32	32	32	32
Front Ring Flange to Panel	G	26	26	26	26	26
Ring Flange to Base	H	0.5	0.5	0.5	0.5	0.5
Base Frame		133.75	154.75	186.75	219.75	219.75
Rear Flange Ring to Base	J	12.5	12.5	12.5	12.5	12.5
<b>HEIGHTS</b>						
Ht Overall	K	134	134	134	134	134
Base to Vent Outlet	L	126	126	126	126	126
Base to Boiler Centerline	M	67	67	67	67	67
Base to Gas Train	N	12	12	12	12	12
Base to Panel Top	T	75	75	75	75	75
Base to Panel Bottom	U	15	15	15	15	15
Height of Base	V	12	12	12	12	12
Base to Steam Nozzle	Y	121.5	123.5	121.5	121	121
<b>WIDTHS</b>						
Width Overall	O	124	124.25	124	124	124
Center to ALWCO	P	57.5	57.5	57.5	57.5	57.5
Center to Outside Control Panel	Q	66.5	66.5	66.5	66.5	66.5
Center to Lagging	R	51	51	51	51	51
Center to WC	S	63	63	63	63	63
Base Inside	W	58.88	58.88	58.88	58.88	58.88
Base Outside	X	71.88	71.88	71.88	71.88	71.88
Boiler I.D.	F	96	96	96	96	96

**Table 5. Model CBLE Steam Boiler Dimensions, 96" (15 - 150 psig design pressure) (Continued)**

Description	DIM	Boiler HP				
		400	500	600	700	800
<b>CONNECTIONS</b>						
Electric - Main Power Supply	AA	460 / 3 / 60	460 / 3 / 60	460 / 3 / 60	460 / 3 / 60	460 / 3 / 60
Surface Blowoff (with collector pipe)	BB	1	1	1	1	1
Steam Outlet 15# (150# Flange)	CC	12	12	12	12	12
Steam Outlet 150# (300# Flange)	CC	6	8	8	8	8
Chemical Feed	FF	1	1	1	1	1
Feed Water (2)	GG	2.5	2.5	2.5	2.5	2.5
Blowdown/Drain (2)	HH	2	2	2	2	2
Water Column Blowdown	JJ	0.75	0.75	0.75	0.75	0.75
Gauge Glass Blowdown	KK	0.25	0.25	0.25	0.25	0.25
<b>VENT STACK</b>						
Diameter (OD) (fgd. connection)		24	24	24	24	24
<b>CLEARANCES</b>						
Rear Door Swing		53	53	53	53	53
Front Door Swing		108	108	108	108	108
Tube Removal, Rear		131	152	184	217	217
Tube Removal, Front		114	135	167	200	200
<b>MINIMUM BOILER ROOM LENGTH ALLOWING FOR DOOR SWING AND TUBE REMOVAL</b>						
From Rear of Boiler		386	428	492	558	558
From Front of Boiler		314	356	420	486	486
Through Window or Doorway		308	329	361	394	394
<b>WEIGHT IN LBS</b>						
Normal Water Capacity		14810	15950	19270	23000	23000
Approx. Ship Wt. 15 psig		33500	37110	42300	49500	49600
Approx. Ship Wt. 150 psig		36570	39970	45025	52050	52150
Approx. Ship Wt. 200 psig		39680	43580	49400	57315	57415



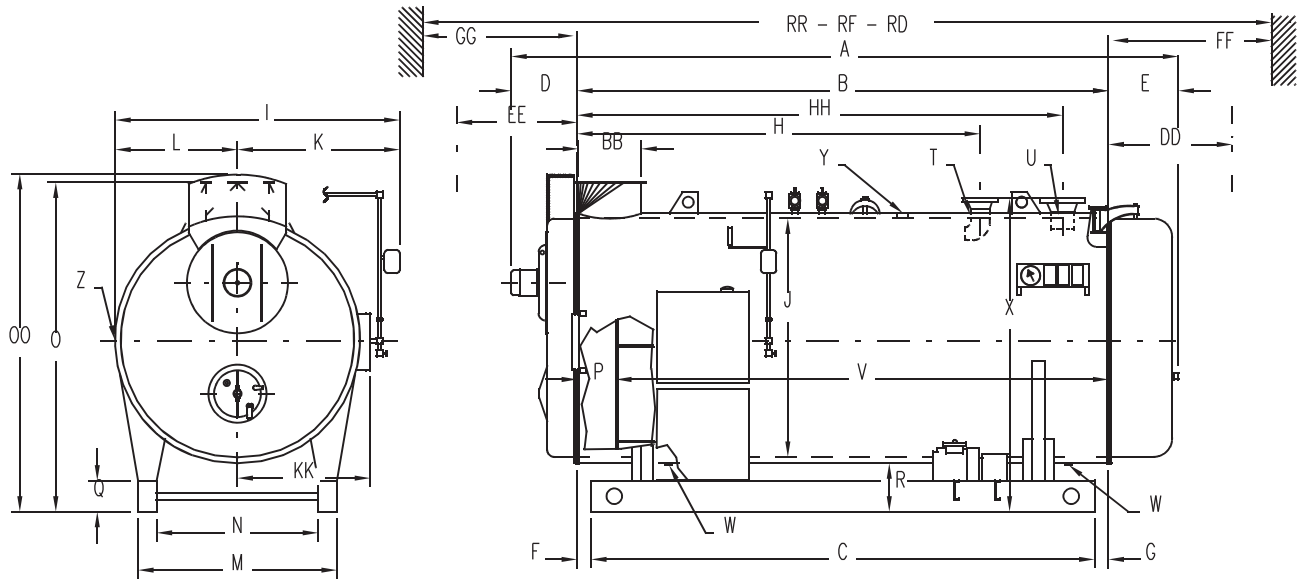

**Table 6. CBLE Hot Water Boiler Dimensions, 60" (30 and 125 psig Design Pressure)**

Description	DIM	Boiler HP		
		125	150	200
<b>LENGTHS</b>				
Overall (60 ppm System)	A	171-1/2	196-1/2	228-1/2
Shell	B	125	149	180
Base Frame	C	112	136	167
Front Head Extension (60 ppm System)	D	27	28	29
Rear Head Extension	E	19-1/2	19-1/2	19-1/2
Front Ring Flange to Outlet	HH	114	136	167
Front Ring Flange to Return	H	89	102	131
Ring Flange to Base	F	1/2	1/2	1/2
Over Tubesheets	V	113	137	168
Shell Extension	P	12	12	12
Rear Flange Ring to Base	G	12-1/2	12-1/2	12-1/2
<b>WIDTHS</b>				
Overall	I	75-1/2	75-1/2	75-1/2
I.D. Boiler	J	60	60	60
Center to Entrance Box	K	42-1/2	42-1/2	42-1/2
Center to Outside Hinge	KK	35	35	35
Center to Lagging	L	33	33	33
Base, Outside	M	52-1/2	52-1/2	52-1/2
Base, Inside	N	44-1/2	44-1/2	44-1/2
<b>HEIGHTS</b>				
Overall	OO	86	86	86
Base to Vent Outlet	O	85	85	85
Base to Return and Outlet	X	82-3/8	82-3/8	82-3/8
Height of Base	Q	12	12	12
Base to Bottom of Boiler	R	16	16	16
<b>BOILER CONNECTIONS</b>				
Auxiliary Connection	Z	1	1	1
Water Return Flange	T	6 <sup>A</sup>	6 <sup>A</sup>	6 <sup>A</sup>
Water Outlet Flange (2" Dip Tube Included)	U	6 <sup>A</sup>	6 <sup>A</sup>	6 <sup>A</sup>

**Table 6. CBLE Hot Water Boiler Dimensions, 60" (30 and 125 psig Design Pressure) (Continued)**

Description	DIM	Boiler HP		
		125	150	200
Drain, Front and Rear	W	1-1/2	1-1/2	2
Air Vent	Y	1-1/2	1-1/2	1-1/2
VENT STACK				
Diameter (flgd. connection)	BB	16	16	16
MINIMUM CLEARANCES				
Rear Door Swing	DD	32	32	32
Front Door Swing	EE	67	67	67
Tube Removal, Rear	FF	115	139	170
Tube, Removal, Front	GG	103	127	158
MINIMUM BOILER ROOM LENGTH ALLOWING FOR DOOR SWING AND TUBE REMOVAL FROM:				
Rear of Boiler	RR	307	355	417
Front of Boiler	RF	260	308	370
Thru Window or Doorway	RD	224	248	279
WEIGHT IN LBS				
Water Capacity Flooded		7670	9295	11130
Approx. Ship. Wgt. – 30 psig		11400	12500	14500
Approx. Ship. Wgt. – 125 psig		11800	12900	14900

NOTES: All connections are threaded unless indicated.

A. ANSI 150 psig flange.

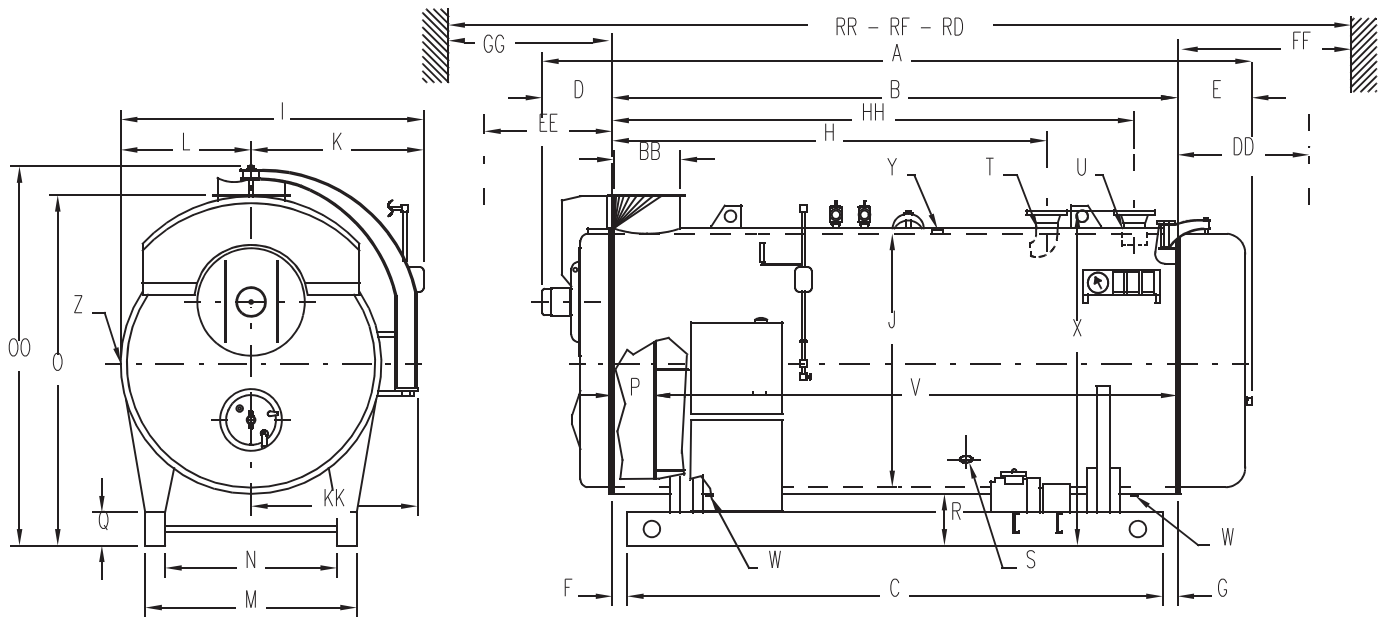

**Table 7. CBLE Hot Water Boiler Dimensions, 78" (30 and 125 psig Design Pressure)**

Description	DIM	Boiler HP		
		250	300	350
<b>LENGTHS</b>				
Overall (60 ppm System)	A	191-1/2	220	252
Shell	B	144	171	201
Base Frame	C	131	158	188
Front Head Extension (60 ppm System)	D	23-1/2	25	27
Rear Head Extension	E	24	24	24
Front Ring Flange to Return	H	103-1/2	130	160
Front Ring Flange to Outlet	HH	131	158	188
Ring Flange to Base	F	1/2	1/2	1/2
Over Tubesheets	V	129	156	186
Shell Extension	P	15	15	15
Rear Flange Ring to Base	G	12-1/2	12-1/2	12-1/2
<b>WIDTHS</b>				
Overall	I	93	93	93
I.D. Boiler	J	78	78	78
Center to Entrance Box	K	51	51	51
Center to Outside Hinge	KK	51	51	51
Center to Lagging	L	42	42	42
Base, Outside	M	64	64	64
Base, Inside	N	52	52	52
<b>HEIGHTS</b>				
Overall	OO	115	115	115
Base to Vent Outlet	O	106	106	106
Base to Return and Outlet	X	101-1/2	101-1/2	101-1/2
Height of Base	Q	10	10	10
Base to Bottom of Boiler	R	17	17	17
<b>BOILER CONNECTIONS</b>				
Waterfill Conn. Right & Left	S	2	2	2-1/2
Auxiliary Connection	Z	1-1/4	1-1/4	1-1/4

**Table 7. CBLE Hot Water Boiler Dimensions, 78" (30 and 125 psig Design Pressure) (Continued)**

Description	DIM	Boiler HP		
		250	300	350
Water Return Flange (2" Dip Tube included)	T	8 <sup>A</sup>	8 <sup>A</sup>	8 <sup>A</sup>
Water Outlet Flange (2" Dip Tube Included)	U	8 <sup>A</sup>	8 <sup>A</sup>	8 <sup>A</sup>
Air Vent	Y	1-1/2	1-1/2	1-1/2
Drain, Front and Rear	W	2	2	2
VENT STACK				
Diameter (flgd. connection)	BB	20	20	20
MINIMUM CLEARANCES				
Rear Door Swing	DD	43	43	43
Front Door Swing	EE	89	89	89
Tube Removal, Rear	FF	131	157	187
Tube, Removal, Front	GG	116	142	172
MINIMUM BOILER ROOM LENGTH ALLOWING FOR DOOR SWING AND TUBE REMOVAL FROM:				
Rear of Boiler	RR	364	417	477
Front of Boiler	RF	303	356	416
Thru Window or Doorway	RD	275	302	332
WEIGHT IN LBS				
Water Capacity Flooded		13880	16840	20090
Approx. Ship. Wgt. – 30 psig		21400	23500	26700
Approx. Ship. Wgt. – 125 psig		22200	24300	27500

NOTES: All connections are threaded unless indicated.

A. ANSI 150 psig flange.

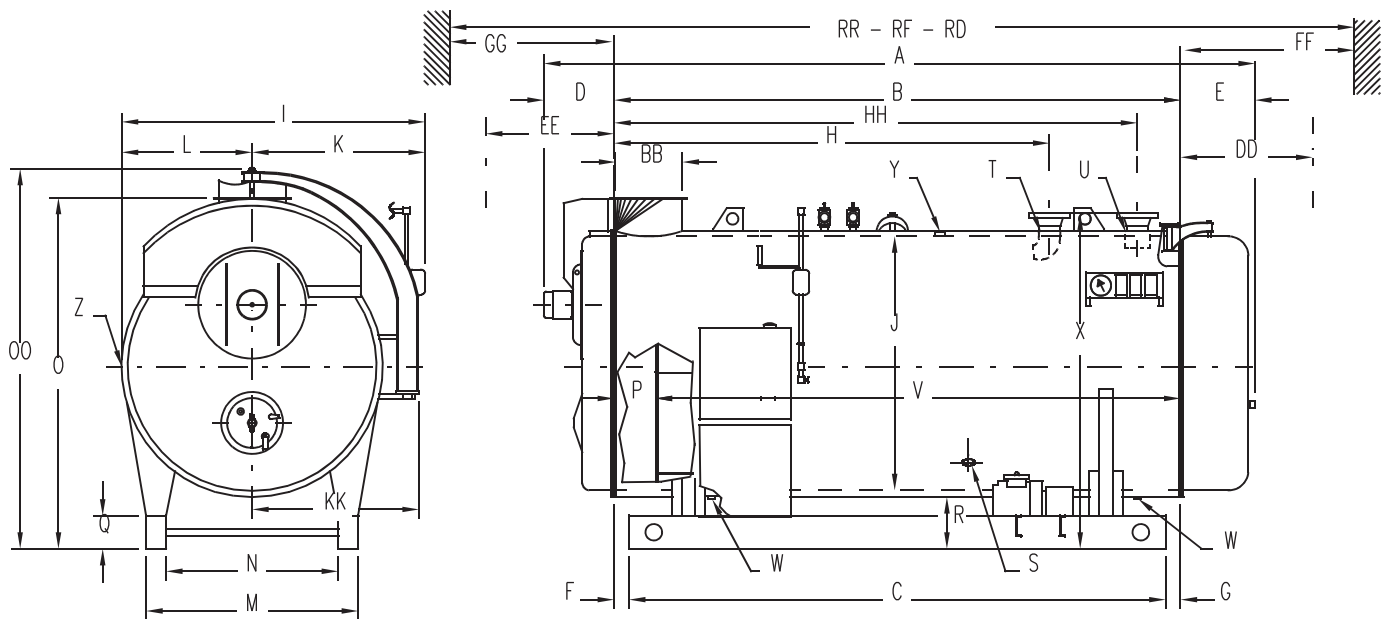

**Table 8. CBLE Hot Water Boiler Dimensions, 96" (30 and 125 psig Design Pressure)**

Description	DIM	Boiler HP				
		400	500	600	700	800
<b>LENGTHS</b>						
Overall (60 ppm System)	A	206	228	262	299	300
Shell	B	147	168	200	233	233
Base Frame	C	134	155	187	220	220
Front Head Extension (60 ppm	D	27	28	30	34	35
Rear Head Extension	E	32	32	32	32	32
Shell Ring Flange to Base	F	1/2	1/2	1/2	1/2	1/2
Rear Ring Flange to Base	G	12-1/2	12-1/2	12-1/2	12-1/2	12-1/2
Shell Flange to Outlet	HH	139-1/2	156-1/2	182-1/2	216-1/2	216-1/2
Shell Flange to Return	H	107	125	151-1/2	185	185
Over Tubesheets	V	130	151	183	216	216
Shell Extension	P	17	17	17	17	17
<b>WIDTHS</b>						
Overall	I	113	113	113	113	115
I.D. Boiler	J	96	96	96	96	96
Center to Entrance Box	K	62	62	62	62	64
Center to Outside Hinge	KK	62	62	62	62	62
Center to Lagging	L	51	51	51	51	51
Base, Outside	M	72	72	72	72	72
Base, Inside	N	56	56	56	56	56
<b>HEIGHTS</b>						
Overall	OO	134	134	134	134	134
Base to Vent Outlet	O	126	126	126	126	126
Height of Base	Q	12	12	12	12	12
Base to Bottom of Boiler	R	19	19	19	19	19
Base to Return and Outlet	X	121-9/16	121-9/16	121-9/16	121-9/16	121-9/16
<b>BOILER CONNECTIONS</b>						
Waterfill Connection, Right and	S	2-1/2	2-1/2	2-1/2	2-1/2	2-1/2
Auxiliary Connection	Z	1-1/4	1-1/4	1-1/4	1-1/4	1-1/4

**Table 8. CBLE Hot Water Boiler Dimensions, 96" (30 and 125 psig Design Pressure) (Continued)**

Description	DIM	Boiler HP				
		400	500	600	700	800
Drain, Front and Rear	W	2	2	2	2	2
Water Return	T	10 <sup>A</sup>	10 <sup>A</sup>	12 <sup>A</sup>	12 <sup>A</sup>	12 <sup>A</sup>
Water Outlet (2" Dip Tube	U	10 <sup>A</sup>	10 <sup>A</sup>	12 <sup>A</sup>	12 <sup>A</sup>	12 <sup>A</sup>
Air Vent	Y	2	2	2	2	2
VENT STACK						
Diameter (Flanged Connection)	BB	24	24	24	24	24
MINIMUM CLEARANCES						
Rear Door Swing	DD	53	53	53	53	53
Front Door Swing	EE	108	108	108	108	108
Tube Removal, Rear	FF	131	152	184	217	217
Tube Removal, Front	GG	114	135	167	200	200
MINIMUM BOILER ROOM LENGTH ALLOWING FOR DOOR SWING AND TUBE REMOVAL FROM:						
Rear of Boiler	RR	386	428	492	558	558
Front of Boiler	RF	314	356	420	486	486
Thru Window or Doorway	RD	308	329	361	394	394
WEIGHT IN LBS						
Normal Water Capacity		20015	23300	28260	33360	33360
Approx. Ship. Wgt. – 30 psig		33300	36900	42150	49650	49750
Approx. Ship. Wgt. – 125 psig		37270	40780	46005	53300	53400

NOTES: All connections are threaded unless indicated.

A. ANSI 150 psig flange.

**Table 9. Model CBLE Blower Motor Selection - Operating Pressures 150 psig and Less, and All Hot Water Boilers**

BOILER HP	MOTOR HP			
	60 PPM	30 PPM	25 PPM	20 PPM
125	5	10	5	10
150	7.5	10	10	10
200	15	15	20	NA
250	7.5	10	15	15
300	10	15	20	25
350	15	25	40	40
400	10	15	20	20
500	15	20	25	30
600	25	30	50	60
700	30	50	75	75
800	50	75	NA	NA

NOTES: For elevations above 700' - contact your local Cleaver-Brooks authorized representative.

**Table 10. Model CB-LE Blower Motor Selection - Operating Pressures Greater than 150 psig (Steam Boilers)**

BOILER HP	MOTOR HP			
	60 PPM	30 PPM	25 PPM	20 PPM
125	5	10	10	10
150	10	10	10	15
200	15	20	20	NA
250	7.5	10	15	20
300	10	20	30	40
350	20	30	40	50
400	10	15	20	25
500	20	25	30	40
600	25	40	60	60
700	40	60	75 <sup>B</sup>	75 <sup>C</sup>
800	60	75 <sup>A</sup>	NA	NA

NOTES: For elevations above 700' - contact your local Cleaver-Brooks authorized representative.

- A. Downrate to 770 hp.
- B. Downrate to 675 hp.
- C. Downrate to 660 hp.