



INTEGRAL BURNER
CBR

FIRETUBE BOILER
Steam and Hot Water 125-800 HP

MODEL CBR

Gas, Oil and Gas/Oil Combinations

Advanced Controls

The Level Master, included on high- pressure steam boilers, provides the safest, most reliable low-water cutoff and level control on the market today.

Upgrade the standard burner management control to the Hawk, a totally integrated, PLC-based control system providing total boiler system control and advanced communications.



Maximum Safety

The model CBR is designed as an integrated package including pressure vessel, burner and controls—all working together to optimize safety. The furnace is placed low within the vessel, affording optimal radiant heat transfer because of a wider temperature differential (Delta T) between the surrounding water and furnace and providing safety due to the greater amount of water above the furnace's top surface area. Additionally, the CBR's integral air-cooled front head, including the burner, offers more safety along with ease of operation and comfort for the operator.

Lowest Emissions

The CBR boiler's integral burner design, including the latest advances in combustion technology, delivers a maximum of 60 PPM NOx when burning natural gas, with an optional 30 PPM burner enhancement. The Cleaver-Brooks CBR boiler is your single-source solution for clearing the air with pure power!

Ease of Maintenance

Hinged or davited doors for easy access, our easy-swing fan and motor assembly not requiring front door opening, integral burner with adjustable fuel/air controls, pullout burner drawer for ease of inspection and adjustment, and retractable oil nozzle all make maintenance a snap.



Flexible Options

Further enhancing the CBR is an array of options to enrich the already outstanding offering. Things to consider include the following:

- Select the Cleaver-Brooks **parallel positioning actuators** in lieu of the standard Acculink@ driver arm system to further enhance the outstanding fuel and air control.
- Select a Cleaver-Brooks **variable speed drive** for controlling the primary combustion air fan to substantially reduce electrical costs, especially if your boiler modulates considerably between low and high fire.
- Select a Cleaver-Brooks **modulating feedwater valve** option to better control the boiler's water level: it works in conjunction with the standard Level Master control on high-pressure steam units.
- Select a Cleaver-Brooks **O2 trim system** to reduce fuel consumption based on varying environmental conditions such as varying barometric pressure, ambient temperature, etc.
- Select the Cleaver-Brooks **Hawk boiler management control**. A totally integrated, PLC-based control system for precise boiler/burner management, safety, interconnectivity and high-powered communications in a single package!

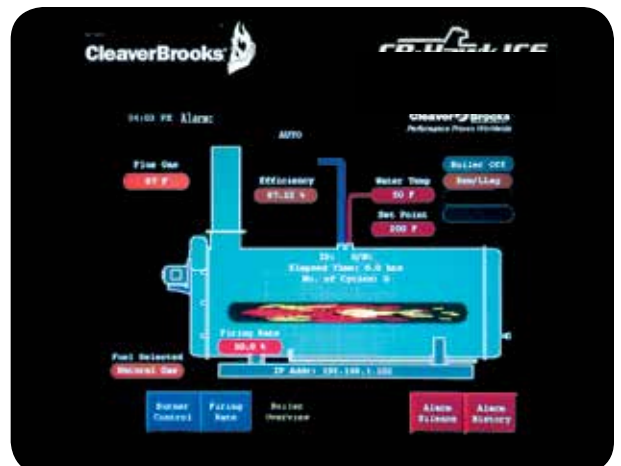

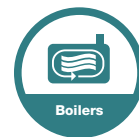

Highly Engineered Package Delivers It All

Integral Design

- Maintains velocities
- Optimal radiant and convective heat transfer
- Saves on energy; low operating cost
- Combination oil/gas firing

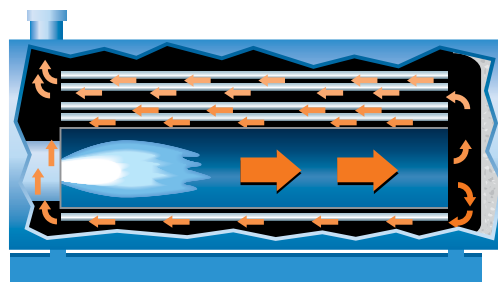

Integral Design

Features and Benefits

- Steam and hot water
- Multiple fuel firing, including No. 6 oil
- Integral burner design
 - Easily installed package
 - Allows interchangeability of burner spare parts for models CB/CBLE/CBR
 - Provides ease of maintenance
 - 60Hz standard and 50Hz with no price surcharge
 - Minimizes the price add-on for altitude correction
- Corrugated furnace is standard equipment
- For international applications, containerization from 125 to 800 HP will reduce delivered-to-jobsite price for large boilers that would otherwise be shipped on flatracks.
- Enhanced heat transfer through the use of "rifled" tubes enables Cleaver-Brooks to reduce the number of tubes, thus reducing the overall weight and shell diameters while maintaining high fuel-to-steam efficiency.

"Hospital Quiet" Operation

The secret to the Cleaver-Brooks CBR "hospital quiet" operation is in the integral burner with caseless fan – simply the most quiet in the industry.

Worldwide Sales, Services and Parts

Go to www.cleaverbrooks.com to find an authorized Cleaver-Brooks representative near you.



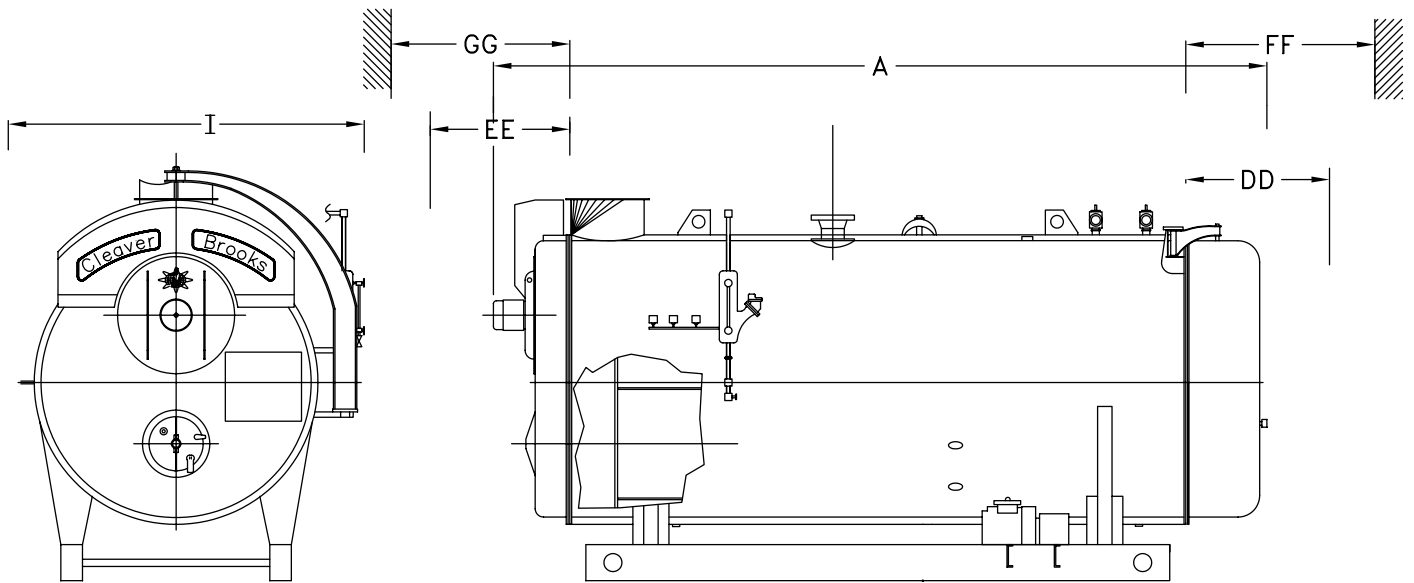

Dimensions and Ratings

All measurements are provided in inches. Measurements are the same for steam and hot water units except where noted.

BOILER HP	DIM	125	150	200	250	300	350	400	500	600	700	800
Overall Length (60 PPM system)	A	196.5	199.5	231.5	207	226	258	224	230	266	300	301
Overall Length (30 PPM system)	A	199.5	200.5	233.5	211	228	260	225	234	267	302	303
Overall Width (HW)	I	75.5	75.5	75.5	82	82	82	100	100	100	100	100
Overall Width (Steam)	I	85	85	85	92	92	92	109	109	109	109	109
Rear Door Swing	DD	32	32	32	36	36	36	45	45	45	45	45
Front Door Swing	EE	67	67	67	75	75	75	80	80	80	80	80
Tube Removal - Rear	FF	139	139	170	143	157	187	147	152	184	217	217
Tube Removal - Front	GG	127	127	158	128	142	172	130	135	167	200	200
RATINGS		Sea level to 3,000 feet										
Rated Capacity (lbs-steam/hr from and at 212 °F)		4,313	5,175	6,900	8,625	10,350	12,075	13,800	17,250	20,700	24,150	27,600
Btu Output (1,000 Btu/hr)		4,184	5,021	6,694	8,368	10,042	11,715	13,389	16,736	20,083	23,430	26,778
EDR steam gross, sq. ft.		17,450	20,920	27,900	34,900	41,850	48,820	55,800	69,750	83,700	97,640	111,600



Packaged Boiler Systems

221 Law Street • Thomasville, GA 31792 USA
 800.250.5883 • info@cleaverbrooks.com
 cleaverbrooks.com