

# **PROFIRE<sup>®</sup>-E SERIES BURNERS**

**8.4 - 42.0 MMBTU/HR**

**High-efficiency burner technology for the most stringent emissions requirements**

# Integration Starts with the Burner

Suitable for firetube, firebox and watertube boilers; the E series features a low-pressure drop firing head design and low blower motor horsepower requirement for increased efficiencies. Advanced technology allows the E series to offer low NOx emissions options, up to 10:1 turndown with natural gas, up to 8:1 turndown with light oil and up to 8:1 turndown with low NOx natural gas.

## Engineered for maximized **EFFICIENCY** and fuel cost savings

ProFire® is the global leader in commercial burners, with a full line of high-quality, low- and ultra-low-emissions burners specifically engineered to increase your boiler's efficiency and decrease fuel costs and emissions.

With innovative features like swing-away housings for easy access and proprietary oil nozzles, compressors and metering pumps, the ProFire line can improve the performance of any boiler, even if it's not a Cleaver-Brooks boiler.



### **Unique Air Damper**

Rotary blade configuration offers precise control of combustion air flow throughout the entire firing range. The unique profile of the rotary damper restricts air flow at low firing ranges leading to increased turndown capability.

### **Efficient Gas Combustion**

Gas is introduced through orifices ahead of the diffuser, providing superior mixing of gas and air with excellent flame retention at all firing rates. The gas manifold is standard on all oil burners for future gas firing.

### **High Turndown**

Up to 10:1 turndown with natural gas and 8:1 with the low NOx option. High turndown allows for reduced heat loss due to short cycling, faster response times to meet load demands and less mechanical cycling.

### **Low Blower Motor HP**

Design includes an air fan with an air foil blade that increases blower efficiency and lowers the blower motor horsepower, thereby increasing year-round electrical utility savings.

### **Parallel Positioning Option**

The use of parallel positioning systems eliminates the need for linkage and reduces setup time. Better control throughout the firing range is also achieved with the use of a parallel positioning system, thus increasing burner efficiency.

### **Combustion Air Impeller**

Highly efficient backward-curved aluminum impeller with the ability to maintain its original balance by avoiding dust collection often seen with forward curved blowers.

# Uncontrolled Emissions Configuration

The Cleaver-Brooks ProFire®E series burner offers: natural gas, propane gas, air atomized #2 oil and combination gas and oil fuel options from 8.4 to 42.0 MMBTU/hr. The LNE burner, capable of <30 PPM NOx emissions offers: natural gas, propane gas, air atomized #2 oil and combination gas and oil fuel options from 8.4 to 42.0 MM BTU/hr. Full modulation operation and cam trim are standard for greater efficiency and cost savings.

## ProFire® - E / LNE

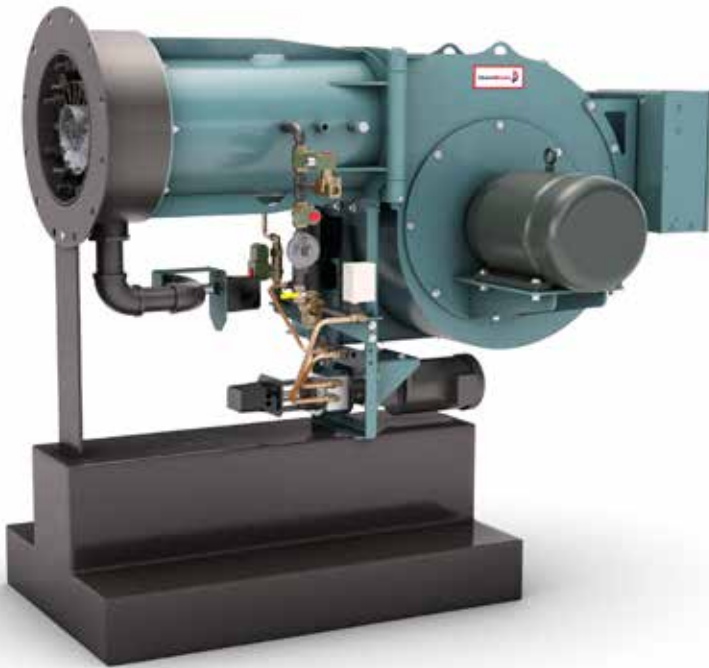

**Low-pressure** air atomizing system on oil with rotary vane compressor.

**Piston-type** positive displacement oil metering system.

**Cam Trim** 14-point adjustment range.

**Parallel Positioning** available for optimal control throughout the firing range.

**Rotary Air Damper** provides precise fuel-to-air ratios.

**Hinged Air Housing** for easy access to internal components.

**Gas Manifold** on oil burners standard for easy upgrade to combination units.

**Combustion Air Fan** efficient airfoil blade design smoothly lifts air flow over the entire blade, resulting in less motor horsepower requirements and significant noise reduction when compared to standard force draft fans.

**Induced FGR** modulating valve and shutoff valve (LNE).

**No. 2 Oil** capability for back-up fuel (LNE).

**UL & ULc** listed.

Emissions	Frame	Model Range	Boiler HP	Capacities		Mode of Operation	Fuel	Parallel Positioning
				MBH	GPH			
Uncontrolled	Size 1-3	84-420	200-1,000	8,400-42,000	60-300	Full Modulation	Gas, Oil, Comb.	Optional
< 30 PPM	Size 1-3	84-420	200-1,000	8,400-42,000	60-300	Full Modulation	Gas & Comb.	Optional



# Capacities and Ratings

## Uncontrolled Emissions Configuration (EL, EG, ELG)

Burner Model & Frame Size	84-1	105-1	126-1	147-1	168-2	210-2	252-2	294-3	336-3	378-3	420-3
Gas Input (MBTU/hr)	8,400	10,500	12,600	14,700	16,800	21,000	25,200	29,400	33,600	37,800	42,000
Oil Input (US gph)	60	75	90	105	120	150	180	210	240	270	300
Boiler HP @ 80% Eff.	200	250	300	350	400	500	600	700	800	900	1,000
Blower Motor HP	5	5	7 1/2	10	15	15	15	20	25	30	40
Separate Compressor Motor HP 3 Phase	3	3	3	5	5	5	7 1/2	7 1/2	7 1/2	15	15
Oil Metering System Motor HP 3 Phase	1/2	1/2	1/2	1/2	1/2	3/4	3/4	3/4	3/4	1	1
Furnace Pressure ("w.c.)	4	4	4	4	6	6	7.5	7	9	8	8
Standard Gas Train Pipe Size (in.)	2.5	3	3	3	3	3	3	3	3	4	4
Gas Pressure Required (PSI)	2.1	2.2	2.5	2.7	3.0	3.9	4.3	2.6	3.1	3.6	3.7
Shipping Weight	1,500	1,500	1,500	1,500	2,200	2,200	2,200	5,000	5,000	5,000	5,000

## <30 PPM Low NOx Configuration (LNEG, LNELG)

Burner Model & Frame Size	84-1	105-1	126-1	147-1	168-2	210-2	252-2	294-3	336-3	378-3	420-3
Gas Input (MBTU/hr)	8,400	10,500	12,600	14,700	16,800	21,000	25,200	29,400	33,600	37,800	42,000
Oil Input (US gph)	60	75	90	105	120	150	180	210	240	270	300
Boiler HP @ 80% Eff.	200	250	300	350	400	500	600	700	800	900	1,000
Blower Motor HP	5	7 1/2	7 1/2	10	15	20	25	30	40	40	50
Separate Compressor Motor HP 3 Phase	3	3	3	5	5	5	7 1/2	7 1/2	7 1/2	15	15
Oil Metering System Motor HP 3 Phase	1/2	1/2	1/2	1/2	1/2	3/4	3/4	3/4	3/4	1	1
Furnace Pressure ("w.c.)	4	4	4	4	6	6	6.5	8	9	8	8
Standard Gas Train Pipe Size (in.)	2.5	3	3	3	3	3	3	3	3	4	4
Gas Pressure Required (PSI)	2.1	2.2	2.5	2.7	3.0	3.9	4.3	2.6	3.1	3.6	3.7
FGR Line Piping Size	6	6	6	6	8	8	8	12	12	12	12
Shipping Weight	2,000	2,000	2,000	2,000	3,000	3,000	3,000	5,500	5,500	5,500	5,500

Input is based on fuel BTU content and altitude of 2,000 feet or less. If altitude > 2,000 feet and < 8,000 feet, derate capacity 4% per 1,000 feet over 2,000. Consult factory for higher altitudes. Gas input is based on natural gas with 1,000 Btu/cu.ft., 0.60 gravity, 0 "w.c. furnace pressure. Oil input based on 140,000 BTU/gal.

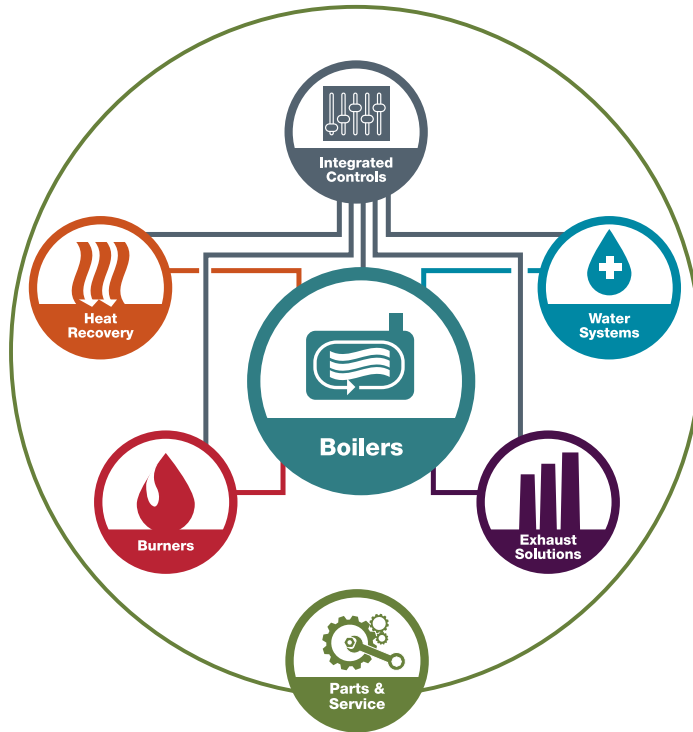

## Total integration doesn't stop with the burner.

Only Cleaver-Brooks offers complete boiler systems, from fuel inlet to stack outlet, that are completely designed, engineered, manufactured, integrated, and serviced by one company.

Integration starts with the burners, and Cleaver-Brooks has been perfecting this integral element of the boiler system through innovation and expert engineering for more than 80 years.



Packaged Burner Systems  
 351 21st Street, Monroe, WI 53566 USA  
 608.325.3141 • [info@cleaverbrooks.com](mailto:info@cleaverbrooks.com)  
[cleaverbrooks.com](http://cleaverbrooks.com)