

CBEX ELITE

100-800 HP



Boiler Book
03/2018



CONTENTS

FEATURES AND BENEFITS	3
PRODUCT OFFERING	3
DIMENSIONS AND RATINGS	4
PERFORMANCE DATA	10
ENGINEERING DATA	12

ILLUSTRATIONS

CBEX Elite Steam Boiler Dimensions, 100-800 HP	6
CBEX Elite Hot Water Boiler Dimensions, 100-800 HP	8
Mounting Piers	20
Stack & Breeching, Multiple Boilers	21

LIST OF TABLES

CBEX Steam Boiler Ratings	5
CBEX Hot Water Boiler Ratings	5
CBEX Elite Steam Boiler Dimensions 100-800 HP	6
CBEX Elite Hot Water Boiler Dimensions 100-800 HP	8
CBEX Fuel-to-Steam Efficiencies Natural Gas (with heat recovery)	10
CBEX Fuel-to-Steam Efficiencies #2 Oil (with heat recovery)	10
CBEX Natural Gas Estimated Emission Levels	11
Predicted sound levels (30ppm systems) at high fire	11
CBEX #2 Oil Estimated Emission Levels	11
Safety valves steam	12
Relief valves hot water.	12
CBEX Elite steam volume and disengaging area	13
CBEX Elite recommended steam nozzle size	13
CBEX Elite recommended Non-Return Valve size	14
Required Gas Pressure at Entrance to C-B Supplied Regulator/Gas Valve; 30/60 ppm	16
Required Gas Pressure at Entrance to C-B Supplied Regulator/Gas Valve; 9 ppm	17
CBEX altitude correction for gas	17
Boiler room width	18
CBEX lifting lugs	19
CBEX Elite boiler mounting piers	20
Front Davit Support	20

FEATURES AND BENEFITS

The CBEX Elite 100-800 HP Firetube boiler is designed, manufactured, and packaged by Cleaver-Brooks. All units are factory fire tested and shipped as a package, ready for quick connection to utilities. In addition to the features provided on all Cleaver-Brooks Firetube boilers, the following features apply to the CBEX.

Two Pass Design:

- The packaged boiler offers high efficiency, flexibility, reliability, safety and ease of operation.

Front and Rear Access:

- Provides access to front tube sheet and furnace.
- Large rear access plug for turnaround and furnace access.

Natural Gas, No. 2 Oil, or Combination Burners Available:

- Combination gas/oil burners provide quick fuel changeover without burner adjustment.

PRODUCT OFFERING

Burners are available to fire natural gas, No. 2 oil, or a combination of oil and gas. Standard product offering for 100-800 HP CBEX boilers is:

- Two pass wetback design.
- 150, 200, or 250 psig steam
- 30 and 125 psig hot water
- Full modulation, all sizes.

Available options include the following (contact your local Cleaver-Brooks authorized representative for option details).

- Boiler Options:
 - Additional screwed or flanged tappings.
 - Blowdown valves.
 - Non-return valves.
 - Feedwater valves and regulators.
 - Surface blowdown systems.
 - Surge load baffles.
 - Seismic design.
- Burner/Control Options:
 - Flame safeguard controllers.
 - Lead/lag system.
 - Special insurance and code requirements (e.g., IRI, FM, NFPA8501).
 - Alarm bell/silence switch.
 - Special motor requirements (TEFC, high efficiency).
 - Special indicating lights.
 - Main disconnect.
 - Elapsed time meter.
 - NEMA enclosures.
 - Remote emergency shut-off (115V).

Circuit breakers.

Day/night controls.

Special power requirements.

Low NOx Equipment.

- Fuel Options:

Gas strainer.

Gas pressure gauge.

Future gas conversion.

Oversized/undersized gas trains.

Optional Oil Pumps.

DIMENSIONS AND RATINGS

Dimensions and ratings are shown in the following tables and illustrations.

NOTE: The following information is subject to change without notice.

Table 1 - CBEX steam boiler ratings

Table 2 - CBEX hot water boiler ratings

Figure 1 / Table 3 - CBEX steam boiler dimensions

Figure 2 / Table 4 - CBEX hot water boiler dimensions

Table 1. CBEX Steam Boiler Ratings

BOILER H.P.	100	125	150	200	250	300	350	400	500	600	700	800
RATINGS - SEA LEVEL TO 700 FT.												
Rated Capacity (lbs-steam/hr from and at 212 °F)	3450	4313	5175	6900	8625	10350	12075	13800	17250	20700	24150	27600
Btu Output (1000 Btu/hr)	3348	4184	5021	6695	8369	10043	11716	13390	16738	20085	23433	26780
APPROXIMATE FUEL CONSUMPTION AT RATED CAPACITY BASED ON NOMINAL 82% EFFICIENCY												
Light Oil gph (140,000 Btu/gal)	29.2	36.4	43.7	58.3	72.9	87.5	102.1	116.6	145.8	175.0	204.1	233.3
Gas CFH (1000 Btu)	4082	5103	6123	8165	10206	12247	14288	16329	20412	24494	28576	32659
Gas (Therm/hr)	40.8	51.0	61.2	81.6	102.1	122.5	142.9	163.3	204.1	244.9	285.8	326.6
POWER REQUIREMENTS - SEA LEVEL TO 700 FT. (60 HZ)												
Blower Motor hp (60 ppm) ^A	7-1/2	7-1/2	5	20	7-1/2	15	15	15	30	40	40	60
Blower Motor hp (30 ppm) ^A	7-1/2	7-1/2	7-1/2	20	15	20	15	20	30	50	40	75
Blower Motor hp (9 ppm) ^A	5	7-1/2	7-1/2	15	15	20	15	25	30	50	75	n/a
Oil Pump Motor, No. 2 Oil	1/3	1/2	1/2	1/2	1/2	3/4	3/4	3/4	3/4	3/4	1	1
Air Compressor Motor hp (No. 2 Oil firing Only)	3	3	3	3	5	5	5	5	7-1/2	7-1/2	7-1/2	7-1/2
BOILER DATA												
Heating Surface sq-ft. (Fireside)	417	485	563	750	879	922	1205	1521	1768	1905	2404	2481

NOTES:

A. Blower motor size for boiler operating pressures 125 psig and less, contact your local Cleaver-Brooks authorized representative for higher pressures and altitude.

Table 2. CBEX Hot Water Boiler Ratings

BOILER H.P.	100	125	150	200	250	300	350	400	500	600	700	800
RATINGS - SEA LEVEL TO 700 FT.												
Btu Output (1000 Btu/hr)	3348	4184	5021	6695	8369	10043	11716	13390	16738	20085	23433	26780
APPROXIMATE FUEL CONSUMPTION AT RATED CAPACITY BASED ON NOMINAL 85% EFFICIENCY												
Light Oil gph (140,000 Btu/gal)	28.1	35.2	42.2	56.3	70.3	84.4	98.4	112.5	140.6	168.8	196.9	225.0
Gas CFH (1000 Btu)	3938	4923	5907	7876	9846	11815	13784	15753	19691	23629	27568	31506
Gas (Therm/hr)	39.4	49.2	59.1	78.8	98.5	118.1	137.8	157.5	196.9	236.3	275.7	315.1
POWER REQUIREMENTS - SEA LEVEL TO 700 FT. (60 HZ)												
Blower Motor hp (60 ppm) ^A	7-1/2	7-1/2	5	20	7-1/2	15	15	15	30	40	40	60
Blower Motor hp (30 ppm) ^A	7-1/2	7-1/2	7-1/2	20	15	20	15	20	30	50	40	75
Blower Motor hp (9 ppm) ^A	5	7-1/2	7-1/2	15	15	20	15	25	30	50	75	n/a
Oil Pump Motor, No. 2 Oil	1/3	1/2	1/2	1/2	1/2	3/4	3/4	3/4	3/4	3/4	1	1
Air Compressor Motor hp (No. 2 Oil firing Only)	3	3	3	3	5	5	5	5	7-1/2	7-1/2	7-1/2	7-1/2
BOILER DATA												
Heating Surface sq-ft. (Fireside)	417	485	563	750	879	922	1205	1521	1768	1905	2404	2481

Figure 1. CBEX Elite Steam Boiler Dimensions, 100-800 HP

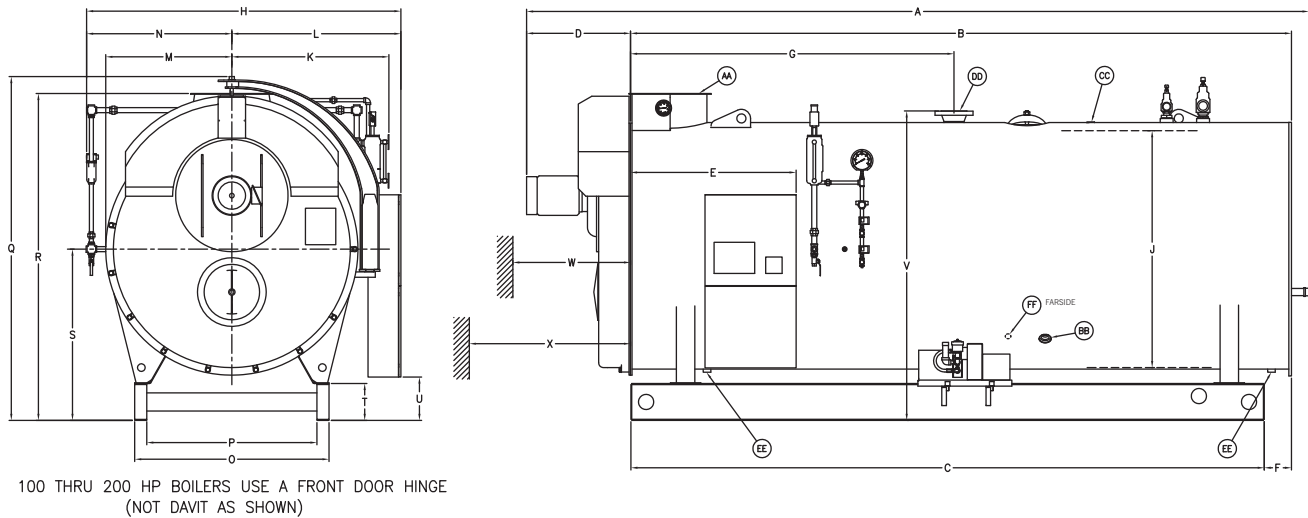

Table 3. CBEX Elite Steam Boiler Dimensions 100-800 HP

BOILER H.P.	DIM	100	125	150	200	250	300	350	400	500	600	700	800
LENGTHS													
Overall Length (60 PPM system)	A	165	172	176.5	201.5	231.5	242.5	249	265	260.5	282.5	291	299
Overall Length (30 PPM system)	A	167	176	180.5	203.5	233.5	243.5	255	268	271.5	287.5	298	307
Overall Length (9 PPM system)	A	167	176	182.5	205.5	233.5	243.5	255	270	271.5	288.5	300	n/a
Shell	B	137.25	144.25	149	168	196	204	217.5	226.5	229	244	253	260
Base Frame	C	129.5	136.5	140	159	186	194	208.5	217.5	219.5	234.5	243.5	250.5
Front Head Extension (60 PPM system)	D	21.5	21.5	21.5	27.5	29.5	32.5	25.5	32.5	25.5	32.5	32	33
Front Head Extension (30 PPM system)	D	23.5	25.5	25.5	29.5	31.5	33.5	31.5	35.5	36.5	37.5	39	41
Front Head Extension (9 PPM system)	D	23.5	25.5	27.5	31.5	31.5	33.5	31.5	37.5	36.5	38.5	41	n/a
Front Ring Flange to Panel	E	46	46	48	48	47	47	57	57	52	52	52	52
Rear Ring Flange to Base	F	7.75	7.75	9	9	10	10	9	9	9.5	9.5	9.5	9.5
Shell Flange to Steam Nozzle	G	62.5	66	73.5	75.5	96.5	100.5	106.5	111	114.5	122	126.5	130
WIDTHS													
Overall Width	H	81	81	86	86	94	94	105	105	112	112	119	119
I.D. Boiler	J	55	55	60	60	67	67	78	78	85	85	92	92
Center to Water Column	K	42.5	42.5	45	45	48.5	48.5	54	54	57.5	57.5	61	61
Center to Panel	L	44.5	44.5	47	47	50.5	50.5	56	56	59.5	59.5	63	63
Center to Lagging	M	30.5	30.5	33	33	36.5	36.5	42	42	45.5	45.5	49	49
Center to Auxiliary LWCO	N	36.5	36.5	39	39	43.5	43.5	49	49	52.5	52.5	56	56
Base Outside	O	47.5	47.5	52.5	52.5	51	51	64	64	60	60	68	68
Base Inside	P	39.5	39.5	44.5	44.5	43	43	56	56	47	47	55	55
HEIGHTS													
Overall Height	Q	81.5	81.5	87	87	101.5	101.5	113	113	122	122	130	130
Base to Vent Outlet	R	81	81	87	87	94.5	94.5	108	108	114.5	114.5	122.5	122.5
Base to Boiler Centerline	S	41	41	46	46	50	50	56.5	56.5	61	61	65.5	65.5
Height of Base Frame	T	12	12	12	12	12	12	12	12	12	12	12	12

Table 3. CBEX Elite Steam Boiler Dimensions 100-800 HP (Continued)

Base to Bottom of Panel	U	17	17	17	17	20	20	24	24	23	23	23	23
Base to Steam Outlet	V	78.5	78.5	82.5	82.5	90	90	102	102	110	110	118	118
BOILER CONNECTIONS													
Feedwater Inlet (Both Sides)	BB	1.25	1.5	1.5	2	2	2	2.5	2.5	2.5	2.5	2.5	2.5
Surface Blowoff	CC	1	1	1	1	1	1	1	1	1	1	1	1
Steam Nozzle (300# ANSI Flange)	DD	4	4	4	4	6	6	6	6	8	8	8	8
Blowdown-Front & Rear	EE	1.25	1.5	1.5	1.5	1.5	1.5	1.5	2	2	2	2	2
Chemical Feed	FF	1	1	1	1	1	1	1	1	1	1	1	1
VENT STACK													
Vent Stack Diameter (Flanged)	AA	16	16	16	16	20	20	24	24	24	24	24	24
MINIMUM CLEARANCES													
Front Door Swing	W	62	62	67	67	78	78	89	89	97	97	104	104
Tube Removal - Front Only	X	89	96	101	120	142	142	160	169	172	187	196	203
MINIMUM BOILER ROOM LENGTH ALLOWING FOR DOOR SWING AND TUBE REMOVAL:													
Thru Window or Door		235.5	242.5	252	271	310	318	342.5	351.5	362	377	393	400
Front of Boiler		262.5	276.5	286	324	374	382	413.5	431.5	437	467	485	499
WEIGHTS IN LBS													
Normal Water Weight		6,550	6,890	8,010	9,060	11,620	12,190	19,340	19,650	20,060	21,620	25,050	25,870
Approx. Shipping Weight - (150psig)		10,650	11,180	12,520	13,900	17,960	18,540	23,970	24,710	29,300	30,900	38,500	39,450

NOTES:

Accompanying dimensions, while sufficiently accurate for layout purposes, must be confirmed for construction by certified dimension diagram/drawing. All connections are threaded unless otherwise indicated.

Figure 2. CBEX Elite Hot Water Boiler Dimensions, 100-800 HP

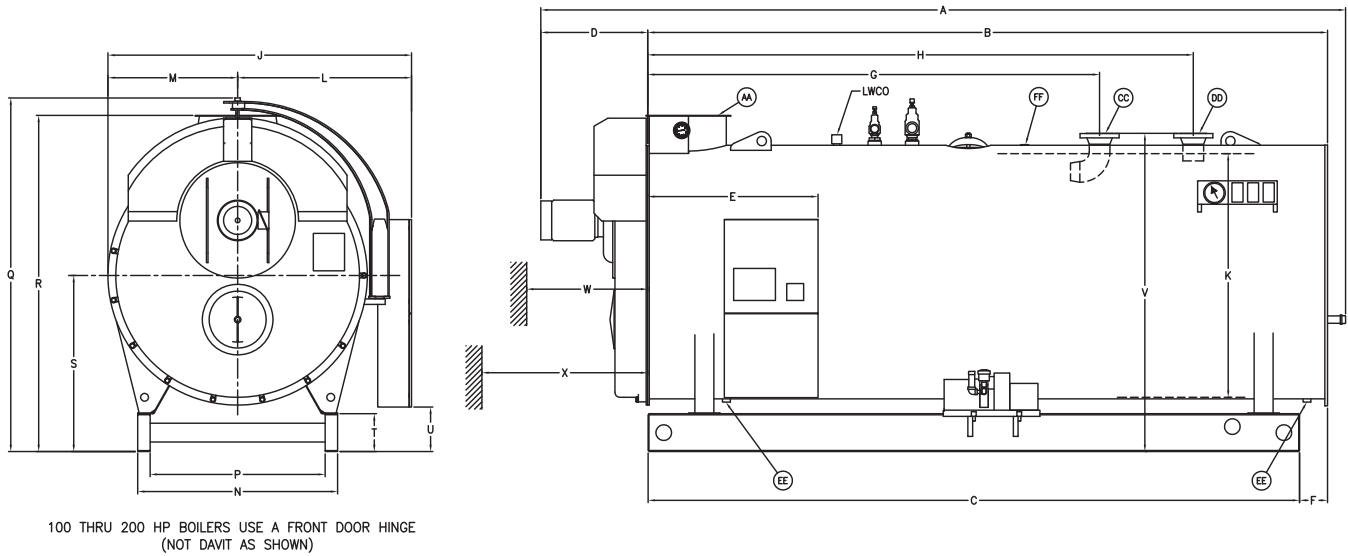

Table 4. CBEX Elite Hot Water Boiler Dimensions 100-800 HP

BOILER H.P.	DIM	100	125	150	200	250	300	350	400	500	600	700	800
LENGTHS													
Overall Length (60 PPM system)	A	165	172	176.5	201.5	231.5	242.5	249	265	260.5	282.5	291	299
Overall Length (30 PPM system)	A	167	176	180.5	203.5	233.5	243.5	255	268	271.5	287.5	298	307
Overall Length (9 PPM system)	A	167	176	182.5	205.5	233.5	243.5	255	270	271.5	288.5	300	n/a
Shell	B	137.25	144.25	149	168	196	204	217.5	226.5	229	244	253	260
Base Frame	C	129.5	136.5	140	159	186	194	208.5	217.5	219.5	234.5	243.5	250.5
Front Head Extension (60 PPM system)	D	21.5	21.5	21.5	27.5	29.5	32.5	25.5	32.5	25.5	32.5	32	33
Front Head Extension (30 PPM system)	D	23.5	25.5	25.5	29.5	31.5	33.5	31.5	35.5	36.5	37.5	39	41
Front Head Extension (9 PPM system)	D	23.5	25.5	27.5	31.5	31.5	33.5	31.5	37.5	36.5	38.5	41	n/a
Front Ring Flange to Panel	E	46	46	48	48	47	47	57	57	52	52	52	52
Rear Ring Flange to Base	F	7.75	7.75	9	9	10	10	9	9	9.5	9.5	9.5	9.5
Shell Flange to Water Return	G	93.5	100.5	105	124	150.5	158.5	172	181	173.5	188.5	197.5	204.5
Shell Flange to Water Outlet	H	118.5	125.5	130	149	176.5	184.5	198	207	209.5	224.5	233.5	240.5
WIDTHS													
Overall Width	J	75	75	80	80	87	87	98	98	105	105	112	112
I.D. Boiler	K	55	55	60	60	67	67	78	78	85	85	92	92
Center to Panel	L	44.5	44.5	47	47	50.5	50.5	56	56	59.5	59.5	63	63
Center to Lagging	M	30.5	30.5	33	33	36.5	36.5	42	42	45.5	45.5	49	49
Base Outside	O	47.5	47.5	52.5	52.5	51	51	64	64	60	60	68	68
Base Inside	P	39.5	39.5	44.5	44.5	43	43	56	56	47	47	55	55
HEIGHTS													
Overall Height	Q	81.5	81.5	87	87	101.5	101.5	113	113	122	122	130	130
Base to Vent Outlet	R	81	81	87	87	94.5	94.5	108	108	114.5	114.5	122.5	122.5
Base to Boiler Centerline	S	41	41	46	46	50	50	56.5	56.5	61	61	65.5	65.5
Height of Base Frame	T	12	12	12	12	12	12	12	12	12	12	12	12

Table 4. CBEX Elite Hot Water Boiler Dimensions 100-800 HP (Continued)

Base to Bottom of Panel	U	17	17	17	17	20	20	24	24	23	23	23	23
Base to Water Return & Outlet	V	78.5	78.5	82.5	82.5	90	90	102	102	110	110	118	118
BOILER CONNECTIONS													
Water Fill (Both Sides)	BB	1.25	1.5	1.5	2	2	2	2.5	2.5	2.5	2.5	2.5	2.5
Water Return (150# ANSI Flange)	CC	4	6	6	6	8	8	8	10	10	12	12	12
Water Outlet (150# ANSI Flange w/Dip Tube)	DD	4	6	6	6	8	8	8	10	10	12	12	12
Drain-Front & Rear	EE	1.5	1.5	1.5	2	2	2	2	2	2	2	2	2
Air Vent	FF	1.5	1.5	1.5	1.5	1.5	1.5	1.5	2	2	2	2	2
VENT STACK													
Vent Stack Diameter (Flanged)	AA	16	16	16	16	20	20	24	24	24	24	24	24
MINIMUM CLEARANCES													
Front Door Swing	W	62	62	67	67	78	78	89	89	97	97	104	104
Tube Removal - Front Only	X	89	96	101	120	142	142	160	169	172	187	196	203
MINIMUM BOILER ROOM LENGTH ALLOWING FOR DOOR SWING AND TUBE REMOVAL:													
Thru Window or Door		235.5	242.5	252	271	310	318	342.5	351.5	362	377	393	400
Front of Boiler		262.5	276.5	286	324	374	382	413.5	431.5	437	467	485	499
WEIGHTS IN LBS													
Normal Water Weight		7,270	7,640	9,200	10,400	14,300	14,970	22,950	23,400	25,950	27,880	33,000	34,000
Approx. Shipping Weight - (30 psig)		9,040	9,510	10,630	11,950	14,900	15,670	20,100	21,420	25,100	26,400	31,350	32,130
Approx. Shipping Weight - (125 psig)		9,900	10,550	12,400	14,150	17,950	18,850	25,000	25,400	31,400	32,950	39,400	40,400

NOTES:

Accompanying dimensions, while sufficiently accurate for layout purposes, must be confirmed for construction by certified dimension diagram/drawing.

All Connections are Threaded Unless Otherwise Indicated:

PERFORMANCE DATA

Efficiency

Tables 5 and 6 show predicted fuel-to-steam efficiencies (including radiation and convection losses) for CBEX Elite boilers (30 ppm). For specific efficiencies on firetube boiler offerings not listed here, contact your local Cleaver-Brooks authorized representative.

Cleaver-Brooks offers an industry leading fuel-to-steam boiler efficiency guarantee for CBEX Firetube Boilers. The guarantee is based on the fuel-to-steam efficiencies shown in the efficiency tables and the following conditions. The efficiency percent number is only meaningful if the specific conditions of the efficiency calculations are clearly stated in the specification (see Cleaver-Brooks publication CB-7767 for a detailed description of efficiency calculations).

The boiler manufacturer shall guarantee that, at the time of startup, the boiler will achieve fuel-to-steam efficiency (as shown in the tables listed above) at 100% firing rate (add efficiency guarantees at 25%, 50%, and 75% of rating, if required). If the boiler(s) fail to achieve the corresponding guaranteed efficiency as published, the boiler manufacturer will rebate, to the ultimate boiler owner, ten thousand dollars (\$10,000) for every full efficiency point (1.0%) that the actual efficiency is below the guaranteed level. The specified boiler efficiency is based on the following conditions.

1. Fuel specification used to determine boiler efficiency:

Natural Gas	No. 2 Oil
Carbon,% (wt) = 69.98	Carbon,% (wt) = 85.8
Hydrogen,% (wt) = 22.31	Hydrogen,% (wt) = 12.7
Sulfur,% (wt) = 0.0	Sulfur,% (wt) = 0.2
Heating value, Btu/lb = 21,830	Heating value, Btu/lb = 19,420

2. Efficiencies are based on ambient air temperature of 80 °F, relative humidity of 30%, and 15% excess air in the exhaust flue gas.
3. Efficiencies are based on the following radiation and convection losses. Firing rate of 25% - 1.2%, 50% - 0.6%, 75% - 0.4%, and 100% - 0.3%.

Table 5. CBEX Fuel-to-Steam Efficiencies Nat. Gas

BHP	OPERATING PRESSURE = 125 psig			
	% OF LOAD			
	25%	50%	75%	100%
100	82.5	82.4	81.9	81.4
125	82.7	82.7	82.5	82.1
150	82.7	82.7	82.5	82.1
200	82.8	83.0	82.9	82.7
250	82.5	82.4	81.9	81.4
300	82.5	82.4	82.0	81.5
350	82.6	82.6	82.3	81.9
400	83.0	82.8	82.5	82.0
500	83.1	82.9	82.6	82.2
600	83.1	83.0	82.7	82.4
700	83.2	83.1	82.9	82.6
800	83.1	83.1	82.8	82.6

Emissions

Table 6. CBEX Natural Gas Estimated Emission Levels

POLLUTANT	UNITS	60 PPM SYSTEM	30 PPM SYSTEM	9 PPM SYSTEM	7 PPM SYSTEM
CO	ppm ^A	10 ^B	10 ^B	25	50
	lb/MMBtu	0.0075	0.0075	0.018	0.037
NOx	ppm ^A	60	30	9	7
	lb/MMBtu	0.07	0.035	0.0105	0.0082
SOx	ppm ^A	1	1	1	1
	lb/MMBtu	0.001	0.001	0.001	0.001
HC/VOC5	ppm ^A	8	8	4	4
	lb/MMBtu	0.0032	0.0032	0.0016	0.0016
PM	ppm ^A	-	-	-	-
	lb/MMBtu	0.01	0.01	0.01	0.01

A. ppm levels are given on a dry volume basis and corrected to 3% oxygen (15% excess air)
 B. 50 ppm CO at low fire up to 300 HP and 10 ppm CO at low fire 350 HP and above

Table 7. Predicted sound levels (30ppm systems) at high fire

BHP	Sound Level-dbA
100	79
125	83
150	83
200	84
250	83
300	84
350	84
400	85
500	85
600	87
700	88
800	90

ENGINEERING DATA

The following engineering information is provided for CBEX Boilers. Additional detail is available from your local Cleaver-Brooks authorized representative.

Boiler Information

Tables 9 and 10 list quantity and outlet size for safety/relief valves supplied on CBEX boilers.

Table 11 shows steam volume and disengaging area.

Table 12 gives recommended steam nozzle sizes.

Table 13 shows recommended non-return valve sizes.

Table 8. Safety valves steam

VALVE SETTING	150 PSIG STEAM		200 PSIG STEAM		250 PSIG STEAM	
BOILER HP	NO. OF VALVES REQ'D	OUTLET SIZE INCHES	NO. OF VALVES REQ'D	OUTLET SIZE INCHES	NO. OF VALVES REQ'D	OUTLET SIZE INCHES
100	1	1-1/2	1	1-1/2	1	1-1/4
125	2	(1) 1-1/2 (1) 1-1/4	2	(1) 1-1/4 (1) 1	2	1
150	2	(1) 1-1/2 (1) 1-1/4	2	(1) 1-1/4 (1) 1	2	1
200	2	1-1/2	2	(1) 1-1/2 (1) 1-1/4	2	1-1/4
250	2	(1) 2 (1) 1-1/2	2	(1) 1-1/2 (1) 1-1/4	2	(1) 1-1/2 (1) 1-1/4
300	2	(1) 2 (1) 1-1/2	2	1-1/2	2	(1) 1-1/2 (1) 1-1/4
350	2	2	2	(1) 2 (1) 1-1/2	2	1-1/2
400	2	(1) 2-1/2 (1) 2	2	(1) 2 (1) 1-1/2	2	(1) 2 (1) 1-1/2
500	2	(1) 2-1/2 (1) 2	2	(1) 2 (1) 2-1/2	2	(1) 2 (1) 1-1/2
600	2	2-1/2	2	(1) 2 (1) 2-1/2	2	2
700, 800	3	(2) 2-1/2 (1) 2	2	2-1/2	2	(1) 2-1/2 (1) 2

NOTE: Valve manufacturers are Kunkle, Consolidated or Conbraco, depending on availability.

Table 9. Relief valves hot water

VALVE SETTING	30 PSIG HW		125 PSIG HW	
BOILER HP	NO. OF VALVES REQ'D	OUTLET SIZE INCHES	NO. OF VALVES REQ'D	OUTLET SIZE INCHES
100	1	2-1/2	1	1-1/4
125	1	2-1/2	1	1-1/4
150	1	2-1/2	1	2
200	2	(1) 2-1/2 (1) 1-1/4	1	2
250	2	(1) 2 (1) 2-1/2	1	2
300	2	2-1/2	1	2-1/2
350	3	(2) 2-1/2 (1) 1	1	2-1/2
400	3	(1) 2 (2) 2-1/2	1	2-1/2
500	4	(1) 1 (3) 2-1/2	2	(1) 1 (1) 2-1/2
600	4	(3) 2-1/2 (1) 2	2	(1) 1-1/4 (1) 2-1/2
700, 800	5	(1) 1 (4) 2-1/2	2	(1) 2-1/2 (1) 2

NOTE: Relief valve is Kunkle #537 for 30# & 125#(Section IV) boiler and is Kunkle #927 for 150# HTHW (Section I) boiler.

Table 10. CBEX Elite steam volume and disengaging area

BOILER HP	STEAM VOLUME CU-FT	STEAM RELIEVING AREA SQ-IN
100	10.2	4291
125	10.7	4522
150	17.6	5544
200	20.1	6322
250	34.3	8597
300	35.8	8971
350	50.7	11059
400	53.0	11563
500	78.9	13550
600	84.5	14515
700	107.2	16517
800	110.3	17006

NOTE:

Based on normal water level.

Based on 150 psig design pressure.

Table 11. CBEX Elite recommended steam nozzle size

OPERATING PRESSURE PSIG	BOILER HP											
	100	125	150	200	250	300	350	400	500	600	700	800
50	4	6	6	6	6	8	8	8	8	10	10	12
75	4	4	4	6	6	6	8	8	8	8	10	10
100	4	4	4	6	6	6	6	6	8	8	8	10
125	4	4	4	4	6	6	6	6	8	8	8	8
150	2.5	3	3	4	4	6	6	6	6	6	8	8
200	2.5	2.5	3	4	4	4	4	6	6	6	6	6
250	2	2.5	2.5	3	4	4	4	4	6	6	6	6

NOTES:

1. Steam nozzle sizes given in inches.
2. Recommended steam nozzle sizes based on 4000 to 5000 fpm steam velocity.

Table 12. CBEX Elite recommended Non-Return Valve size

BOILER HP	BOILER CAPACITY (LBS/HR)	OPERATING PRESSURE (PSIG)							
		50	75	100	125	150	175	200	250
100	3450	2-1/2	2-1/2	NA	NA	NA	NA	NA	NA
125	4313	3	2-1/2	2-1/2	2-1/2	NA	NA	NA	NA
150	5175	3	3	2-1/2	2-1/2	2-1/2	2-1/2	NA	NA
200	6900	3	3	3	3	3	2-1/2	2-1/2	2-1/2
250	8625	4	3	3	3	3	3	3	3
300	10350	4	4	4	3	3	3	3	3
350	12025	4	4	4	4	4	3	3	3
400	13800	5	4	4	4	4	4	4	3
500	17210	6	5	5	4	4	4	4	4
600	20700	6	6	5	5	5	4	4	4
700	24150	6	6	6	5	5	5	5	4
800	27600	6	6	6	6	6	5	5	5

NOTE: Valve sizes (300 psig flanges) given in inches.

Blowdown Water Requirements

Some local codes require blowdown tanks to be constructed in accordance with recommendations of the National Board of Boiler and Pressure Vessel Inspectors.

The National Board's recommendations base the size of the blowdown tank on the removal of at least 4 inches of water from the boiler.

Table 14 lists the approximate quantity of water represented by 4 inches of water at normal operating level for Cleaver-Brooks CBEX Boilers.

Table 13: Blowdown tank sizing

BOILER HP	WATER (GAL)
100	84
125	89
150	106
200	120
250	161
300	167
350	205
400	214
500	247
600	264
700	300
800	309

NOTE: Quantity of water removed from boiler by lowering normal water line 4".

Burner Characteristics

Note that altitude correction and burner changes are required for higher altitudes which may alter dimensions, motor hp and gas pressures. Also 50 Hz applications and low NOx options should be reviewed by the Cleaver-Brooks authorized representative.

Fuel Connections - Gas

The local gas company should be consulted for requirements and authorization for installation and inspection of gas supply piping. Installation of gas supply piping and venting must be in accordance with all applicable engineering guidelines and regulatory codes. All connections made to the boiler should be arranged so that all components remain accessible for inspection, cleaning and maintenance.

A drip leg should be installed in the supply piping before the connection to the gas pressure regulator. The drip leg should be at least as large as the inlet fitting supplied with the boiler. Consideration must be given to both volume and pressure requirements when choosing gas supply piping size. Refer to the boiler dimension diagram provided by Cleaver-Brooks for the particular installation. Connections to the burner gas train should be made with a union, so that gas train components or the burner may be easily disconnected for inspection or service. Upon completion of the gas piping installation, the system should be checked for gas leakage and tight shutoff of all valves.

Fuel Connections - Oil

Oil-fired burners are equipped with an oil pump, which draws fuel from a storage tank and supplies pressurized oil to the burner nozzle(s). The burner supply oil pump has a greater capacity than the burner requires for the maximum firing rate. Fuel not delivered to the nozzle is returned to the storage tank. A two-pipe (supply and return) oil system is recommended for all installations. Oil lines must be sized for the burner and burner supply oil pump capacities.

The burner supply oil pump suction should not exceed 10" Hg. If a transfer pump is used, it must have a pumping capacity at least equal to that of the burner pump(s). Supply pressure to the burner pump should not exceed 3 psig.

A strainer must be installed in the supply piping upstream of the burner supply pump in order to prevent entry of foreign material into the pump, fuel control valves, or burner nozzle(s). The strainer must be sized for the burner supply pump capacity. A strainer mesh of 150 microns (0.005") is recommended.

Install a check valve in the line to prevent draining of the oil suction line when the burner is not in operation. Location of the check valve varies with the system, but usually it is located as close as possible to the storage tank.

Installation of a vacuum gauge in the burner supply line between the burner oil pump and the strainer is recommended. Regular observation and recording of the gauge indication will assist in determining when the strainer needs servicing.

Upon completion of the oil piping installation, the system should be checked for oil or air leakage and tight shutoff of all valves.

Table 14. Required Gas Pressure at Entrance to C-B Supplied Regulator/Gas Valve; 30/60 ppm

BOILER HP	GAS TRAIN SIZE	UPSTREAM VALVE*	DOWN-STREAM*	30 ppm	60 ppm
100 HP	1.5 in	BB	BB	0.7 - 3.1 psi	0.7 - 3.1 psi
100 HP	1.5 in	PC	PC	0.7 - 2.9 psi	0.7 - 2.9 psi
100 HP	2.0 in	BB	BB	0.5 - 0.7 psi	0.5 - 0.7 psi
100 HP	2.0 in	PC	PC	0.5 - 0.7 psi	0.5 - 0.7 psi
100 HP	2.5 in	PC	PC	0.4 - 0.5 psi	0.4 - 0.5 psi
100 HP	3.0 in	PC	PC	0.4 - 0.4 psi	0.4 - 0.4 psi
100 HP	4.0 in	PC	PC	0.4 - 0.4 psi	0.4 - 0.4 psi
125 HP	1.5 in	BB	BB	0.9 - 4.4 psi	0.9 - 4.7 psi
125 HP	1.5 in	PC	PC	1.0 - 4.2 psi	1.0 - 4.4 psi
125 HP	2.0 in	BB	BB	0.8 - 0.9 psi	0.7 - 0.9 psi
125 HP	2.0 in	PC	PC	0.8 - 1.0 psi	0.7 - 1.0 psi
125 HP	2.5 in	PC	PC	0.6 - 0.8 psi	0.6 - 0.7 psi
125 HP	3.0 in	PC	PC	0.6 - 0.6 psi	0.5 - 0.6 psi
125 HP	4.0 in	PC	PC	0.5 - 0.6 psi	0.5 - 0.5 psi
150 HP	1.5 in	BB	BB	1.2 - 5.0 psi	1.2 - 5.0 psi
150 HP	1.5 in	PC	PC	1.3 - 5.0 psi	1.3 - 5.0 psi
150 HP	2.0 in	BB	BB	0.9 - 1.2 psi	0.9 - 1.2 psi
150 HP	2.0 in	PC	PC	0.9 - 1.3 psi	0.9 - 1.3 psi
150 HP	2.5 in	PC	PC	0.7 - 0.9 psi	0.7 - 0.9 psi
150 HP	3.0 in	PC	PC	0.7 - 0.7 psi	0.7 - 0.7 psi
150 HP	4.0 in	PC	PC	0.6 - 0.7 psi	0.6 - 0.7 psi
200 HP	1.5 in	BB	BB	2.0 - 5.0 psi	1.9 - 5.0 psi
200 HP	1.5 in	PC	PC	2.2 - 5.0 psi	2.1 - 5.0 psi
200 HP	2.0 in	BB	BB	1.5 - 2.0 psi	1.4 - 1.9 psi
200 HP	2.0 in	PC	PC	1.5 - 2.2 psi	1.5 - 2.1 psi
200 HP	2.5 in	PC	PC	1.1 - 1.5 psi	1.1 - 1.4 psi
200 HP	3.0 in	PC	PC	1.0 - 1.1 psi	1.0 - 1.1 psi
200 HP	4.0 in	PC	PC	0.9 - 1.0 psi	0.9 - 1.0 psi
250 HP	1.5 in	BB	BB	2.3 - 2.6 psi	2.4 - 2.7 psi
250 HP	1.5 in	PC	PC	2.6 - 2.7 psi	2.8 - 2.8 psi
250 HP	2.0 in	BB	BB	1.5 - 2.3 psi	1.6 - 2.4 psi
250 HP	2.0 in	PC	PC	1.6 - 2.6 psi	1.7 - 2.8 psi
250 HP	2.5 in	PC	PC	1.0 - 1.5 psi	1.1 - 1.6 psi
250 HP	3.0 in	PC	PC	0.8 - 1.0 psi	1.0 - 1.1 psi
250 HP	4.0 in	PC	PC	0.7 - 0.8 psi	0.9 - 1.0 psi
300 HP	1.5 in - 2.0 in	BB	BB	2.9 - 3.4 psi	2.9 - 3.5 psi
300 HP	1.5 in - 2.0 in	PC	PC	3.2 - 3.4 psi	3.2 - 3.5 psi
300 HP	2.0 in	BB	BB	1.9 - 2.9 psi	2.0 - 2.9 psi
300 HP	2.0 in	PC	PC	2.0 - 3.2 psi	2.1 - 3.2 psi
300 HP	2.5 in	PC	PC	1.4 - 1.9 psi	1.5 - 2.0 psi
300 HP	3.0 in	PC	PC	1.1 - 1.4 psi	1.2 - 1.5 psi
300 HP	4.0 in	PC	PC	0.9 - 1.1 psi	1.0 - 1.2 psi

BOILER HP	GAS TRAIN SIZE	UPSTREAM VALVE	DOWN-STREAM	30 ppm	60 ppm
350 HP	1.5 in - 2.0 in	BB	BB	3.6 - 5.0 psi	3.6 - 5.0 psi
350 HP	1.5 in - 2.0 in	PC	PC	4.0 - 5.0 psi	4.0 - 5.0 psi
350 HP	2.0 in	BB	BB	2.7 - 3.6 psi	2.6 - 3.6 psi
350 HP	2.0 in	PC	PC	2.8 - 4.0 psi	2.8 - 4.0 psi
350 HP	2.5 in	PC	PC	1.6 - 2.7 psi	1.5 - 2.6 psi
350 HP	3.0 in	PC	PC	1.2 - 1.6 psi	1.1 - 1.5 psi
350 HP	4.0 in	PC	PC	1.0 - 1.2 psi	0.9 - 1.1 psi
400 HP	1.5 in - 2.0 in	BB	BB	4.6 - 5.0 psi	4.6 - 5.0 psi
400 HP	1.5 in - 2.0 in	PC	PC	5.1 - 7.7 psi	5.2 - 7.8 psi
400 HP	2.0 in	BB	BB	3.2 - 4.6 psi	3.2 - 4.6 psi
400 HP	2.0 in	PC	PC	3.4 - 5.0 psi	3.4 - 5.0 psi
400 HP	2.0 in - 2.5 in	BB	PC	3.0 - 3.2 psi	3.0 - 3.2 psi
400 HP	2.0 in - 2.5 in	PC	PC	3.1 - 3.4 psi	3.1 - 3.4 psi
400 HP	2.5 in	PC	PC	1.8 - 3.0 psi	1.9 - 3.0 psi
400 HP	3.0 in	PC	PC	1.4 - 1.8 psi	1.4 - 1.9 psi
400 HP	4.0 in	PC	PC	1.1 - 1.4 psi	1.1 - 1.4 psi
500 HP	2.0 in - 2.5 in	BB	PC	4.5 - 5.0 psi	4.6 - 5.0 psi
500 HP	2.0 in - 2.5 in	PC	PC	4.7 - 5.0 psi	4.7 - 5.0 psi
500 HP	2.5 in	PC	PC	2.7 - 4.5 psi	2.7 - 4.6 psi
500 HP	3.0 in	PC	PC	2.0 - 2.7 psi	2.0 - 2.7 psi
500 HP	4.0 in	PC	PC	1.5 - 2.0 psi	1.6 - 2.0 psi
600 HP	2.0 in - 2.5 in	BB	PC	6.4 - 9.7 psi	6.4 - 9.5 psi
600 HP	2.0 in - 2.5 in	PC	PC	6.7 - 10.0 psi	6.6 - 9.9 psi
600 HP	2.0 in - 3.0 in	BB	PC	6.2 - 6.4 psi	6.1 - 6.4 psi
600 HP	2.0 in - 3.0 in	PC	PC	6.4 - 6.7 psi	6.3 - 6.6 psi
600 HP	2.5 in	PC	PC	3.8 - 5.0 psi	3.7 - 5.0 psi
600 HP	2.5 in - 3.0 in	PC	PC	3.6 - 3.8 psi	3.5 - 3.7 psi
600 HP	3.0 in	PC	PC	2.7 - 3.6 psi	2.6 - 3.5 psi
600 HP	4.0 in	PC	PC	2.1 - 2.7 psi	2.0 - 2.6 psi
700 HP	2.0 in - 3.0 in	BB	PC	8.5 - 12.8 psi	8.5 - 12.8 psi
700 HP	2.0 in - 3.0 in	PC	PC	8.8 - 13.2 psi	8.8 - 13.2 psi
700 HP	2.5 in - 3.0 in	PC	PC	4.6 - 5.0 psi	4.6 - 5.0 psi
700 HP	3.0 in	PC	PC	3.4 - 4.6 psi	3.4 - 4.6 psi
700 HP	4.0 in	PC	PC	2.6 - 3.4 psi	2.6 - 3.4 psi
800 HP	2.0 in - 3.0 in	BB	PC	10.5 - 15.0 psi	10.5 - 15.0 psi
800 HP	2.0 in - 3.0 in	PC	PC	10.9 - 15.0 psi	10.9 - 15.0 psi
800 HP	2.5 in - 3.0 in	PC	PC	5.8 - 10.0 psi	5.8 - 10.0 psi
800 HP	3.0 in	PC	PC	4.5 - 5.0 psi	4.5 - 5.0 psi
800 HP	4.0 in	PC	PC	3.2 - 4.5 psi	3.2 - 4.5 psi

*BB = Butterball; PC = Plug Cock

Note: For undersized or oversized gas trains or altitudes above 700 feet, contact your local Cleaver-Brooks representative.

Standard Gas Train size is highlighted

Table 15. Required Gas Pressure at Entrance to C-B Supplied Regulator/Gas Valve; 9 ppm

BOILER HP	GAS TRAIN SIZE	UPSTREAM VALVE*	DOWNSTREAM VALVE*	PRESSURE
100 HP	1.5 in	BB	BB	2.3 - 3.5 psi
100 HP	1.5 in	PC	PC	2.4 - 3.6 psi
100 HP	2.0 in	BB	BB	2.2 - 2.3 psi
100 HP	2.0 in	PC	PC	2.2 - 2.4 psi
100 HP	2.5 in	PC	PC	2.2 - 2.2 psi
100 HP	3.0 in	PC	PC	2.1 - 2.2 psi
100 HP	4.0 in	PC	PC	2.1 - 2.1 psi
125 HP	1.5 in	BB	BB	3.3 - 4.9 psi
125 HP	1.5 in	PC	PC	3.4 - 5.0 psi
125 HP	2.0 in	BB	BB	3.1 - 3.3 psi
125 HP	2.0 in	PC	PC	3.1 - 3.4 psi
125 HP	2.5 in	PC	PC	3.0 - 3.1 psi
125 HP	3.0 in	PC	PC	2.9 - 3.0 psi
125 HP	4.0 in	PC	PC	2.9 - 2.9 psi
150 HP	1.5 in	BB	BB	3.4 - 5.1 psi
150 HP	1.5 in	PC	PC	3.6 - 5.3 psi
150 HP	2.0 in	BB	BB	3.1 - 3.4 psi
150 HP	2.0 in	PC	PC	3.2 - 3.6 psi
150 HP	2.5 in	PC	PC	3.0 - 3.1 psi
150 HP	3.0 in	PC	PC	2.9 - 3.0 psi
150 HP	4.0 in	PC	PC	2.9 - 2.9 psi
200 HP	1.5 in	BB	BB	4.9 - 7.3 psi
200 HP	1.5 in	PC	PC	5.1 - 7.6 psi
200 HP	2.0 in	BB	BB	4.4 - 4.9 psi
200 HP	2.0 in	PC	PC	4.4 - 5.1 psi
200 HP	2.5 in	PC	PC	4.0 - 4.4 psi
200 HP	3.0 in	PC	PC	3.9 - 4.0 psi
200 HP	4.0 in	PC	PC	3.8 - 3.9 psi
250 HP	1.5 in	BB	BB	4.2 - 6.4 psi
250 HP	1.5 in	PC	PC	4.6 - 6.9 psi
250 HP	2.0 in	BB	BB	3.4 - 4.2 psi
250 HP	2.0 in	PC	PC	3.5 - 4.6 psi
250 HP	2.5 in	PC	PC	3.0 - 3.4 psi
250 HP	3.0 in	PC	PC	2.9 - 3.0 psi
250 HP	4.0 in	PC	PC	2.7 - 2.9 psi
300 HP	1.5 in - 2.0 in	BB	BB	5.7 - 8.6 psi
300 HP	1.5 in - 2.0 in	PC	PC	6.0 - 9.0 psi
300 HP	2.0 in	BB	BB	4.8 - 5.7 psi
300 HP	2.0 in	PC	PC	4.9 - 6.0 psi
300 HP	2.5 in	PC	PC	4.3 - 4.8 psi
300 HP	3.0 in	PC	PC	4.1 - 4.3 psi
300 HP	4.0 in	PC	PC	3.9 - 4.1 psi

BOILER HP	GAS TRAIN SIZE	UPSTREAM VALVE*	DOWNSTREAM VALVE*	PRESSURE
350 HP	1.5 in - 2.0 in	BB	BB	6.4 - 9.7 psi
350 HP	1.5 in - 2.0 in	PC	PC	6.9 - 10.3 psi
350 HP	2.0 in	BB	BB	5.5 - 6.4 psi
350 HP	2.0 in	PC	PC	5.7 - 6.9 psi
350 HP	2.5 in	PC	PC	4.4 - 5.5 psi
350 HP	3.0 in	PC	PC	4.0 - 4.4 psi
350 HP	4.0 in	PC	PC	3.8 - 4.0 psi
400 HP	1.5 in - 2.0 in	BB	BB	7.8 - 11.7 psi
400 HP	1.5 in - 2.0 in	PC	PC	8.3 - 12.5 psi
400 HP	2.0 in	BB	BB	6.4 - 7.8 psi
400 HP	2.0 in	PC	PC	6.6 - 8.3 psi
400 HP	2.0 in - 2.5 in	BB	PC	6.2 - 6.4 psi
400 HP	2.0 in - 2.5 in	PC	PC	6.3 - 6.6 psi
400 HP	2.5 in	PC	PC	5.0 - 6.2 psi
400 HP	3.0 in	PC	PC	4.6 - 5.0 psi
400 HP	4.0 in	PC	PC	4.3 - 4.6 psi
500 HP	1.5 in - 2.5 in	BB	PC	7.7 - 11.6 psi
500 HP	1.5 in - 2.5 in	PC	PC	8.4 - 12.7 psi
500 HP	2.0 in - 2.5 in	BB	PC	5.8 - 7.7 psi
500 HP	2.0 in - 2.5 in	PC	PC	5.9 - 8.4 psi
500 HP	2.5 in	PC	PC	3.9 - 5.8 psi
500 HP	3.0 in	PC	PC	3.2 - 3.9 psi
500 HP	4.0 in	PC	PC	2.8 - 3.2 psi
600 HP	2.0 in - 2.5 in	BB	PC	8.1 - 12.1 psi
600 HP	2.0 in - 2.5 in	PC	PC	8.3 - 12.4 psi
600 HP	2.0 in - 3.0 in	BB	PC	7.8 - 8.1 psi
600 HP	2.0 in - 3.0 in	PC	PC	8.0 - 8.3 psi
600 HP	2.5 in	PC	PC	5.5 - 7.8 psi
600 HP	2.5 in - 3.0 in	PC	PC	5.2 - 5.5 psi
600 HP	3.0 in	PC	PC	4.3 - 5.2 psi
600 HP	4.0 in	PC	PC	3.7 - 4.3 psi
700 HP	2.0 in - 3.0 in	BB	PC	11.0 - 15.0 psi
700 HP	2.0 in - 3.0 in	PC	PC	11.3 - 15.0 psi
700 HP	2.5 in - 3.0 in	PC	PC	7.0 - 10.0 psi
700 HP	3.0 in	PC	PC	5.9 - 7.0 psi
700 HP	4.0 in	PC	PC	5.0 - 5.9 psi

*BB = Butterball; PC = Plug Cock

Note: For undersized or oversized gas trains or altitudes above 700 feet, contact your local Cleaver-Brooks representative.

Standard Gas Train size is highlighted

Table 16. CBEX altitude correction for gas

ALTITUDE (FT)	CORRECTION FACTOR	ALTITUDE (FT)	CORRECTION FACTOR
1000	1.04	6000	1.25
2000	1.07	7000	1.3
3000	1.11	8000	1.35
4000	1.16	9000	1.4
5000	1.21	-	-

To obtain min. req. gas pressure at altitudes above 700 feet, multiply pressure by the listed factors.
 Inches WC x 0.577 = oz/sq-in.
 oz/sq-in x 1.732 = inches WC.
 Inches WC x 0.0361 = psig.
 oz/sq-in x 0.0625 = psig.
 psig x 27.71 = Inches WC.
 psig x 16.0 = oz/sq-in.

Boiler Room Information

Table 17 shows typical boiler room width requirements.

BOILER HP	100-125	150-200	250-300	350-400	500-600	700-800
DIM. "A"	86	88	92	98	102	105
DIM. "B"	120	127	144	151	174	178

NOTES:

1. Recommended Minimum Distance Between Boiler and Wall. Dimension "A" allows for a clear 42" aisle between the water column on the boiler and the wall. If space permits, this aisle should be widened.
2. Recommended Minimum Distance Between Boilers. Dimension "B" between boilers allows for a "clear" aisle of:
 - 42" - 100-200 HP
 - 48" - 250-400 HP
 - 60" - 500-800 HP
 If space permits, this aisle should be widened.

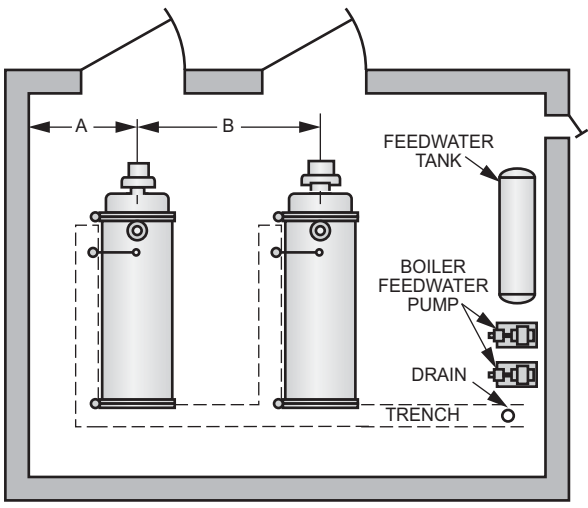

Stack Support Capabilities

CBEX boilers can support up to 2000 lbs. without additional support.

CBEX boilers can be reinforced to support up to 3000 lbs.

Boiler Room Combustion Air

When determining boiler room air requirements, the size of the room, air flow, and velocity of air must be reviewed as follows:

1. Size (area) and location of air supply openings in boiler room.
 - A. Two (2) permanent air supply openings in the outer walls of the boiler room are recommended. Locate one (1) at each end of the boiler room, preferably below a height of 7 feet. This allows air to sweep the length of the boiler.
 - B. Air supply openings can be louvered for weather protection, but they should not be covered with fine mesh wire, as this type of covering has poor air flow qualities and is subject to clogging by dust or dirt.
 - C. A vent fan in the boiler room is not recommended, as it could create a slight vacuum under certain conditions and cause variations in the quantity of combustion air. This can result in unsatisfactory burner performance.
 - D. Under no condition should the total area of the air supply openings be less than one (1) square foot.
 - E. Size the openings by using the formula:

$$\text{Area (sq-ft)} = \text{CFM/FPM}$$

2. Amount of air required (cfm).
 - A. Combustion Air = Rated bhp x 8 cfm/bhp.
 - B. Ventilation Air = Maximum bhp x 2 cfm/bhp or a total of 10 cfm/bhp - up to 1000 feet elevation. Add 3 percent more per 1000 feet of added elevation.
3. Acceptable air velocity in Boiler Room (fpm).
 - A. From floor to (7) foot height - 250 fpm.
 - B. Above (7) foot height - 500 fpm.

Example: Determine the area of the boiler room air supply openings for (1) 1000 hp boiler at 800

feet altitude. The air openings are to be 5 feet above floor level.

- Air required: $1000 \times 10 = 10000$ cfm (from 2B above).
- Air velocity: Up to 7 feet = 250 fpm (from 3 above).
- Area Required: $\text{Area} = \text{cfm}/\text{fpm} = 10000/250 = 40$ Sq-ft total.
- Area/Opening: $40/2 = 20$ sq-ft/opening (2 required).

Consult local codes, which may supersede these requirements.

NOTE for <9ppm, <7ppm, and <5ppm applications (NT and LNO burners):

Boiler air inlets must not be connected to a common manifold. Care must be taken to ensure minimal changes in boiler room static pressure throughout operation.

Table 18. CBEX lifting lugs

BOILER HP	ALL DIMENSIONS IN INCHES				
	A	B	C	D	E
100	75.25	21.375	101.75	10	3
125	75.25	21.375	108.75	10	3
150	79.5	21.375	102.5	10	3
200	79.5	21.375	121.5	10	3
250	87.25	27.5	131.25	10	3
300	87.25	27.5	139.25	10	3
350	99.5	36.375	144	10	3
400	99.5	36.375	153	10	3
500	107.625	36.5	162	10	3
600	107.625	36.5	177	10	3
700	115.75	37.75	183.5	10	3
800	115.75	37.75	190.5	10	3

NOTE: Dimensions A, B, and C may vary by 1 inch.

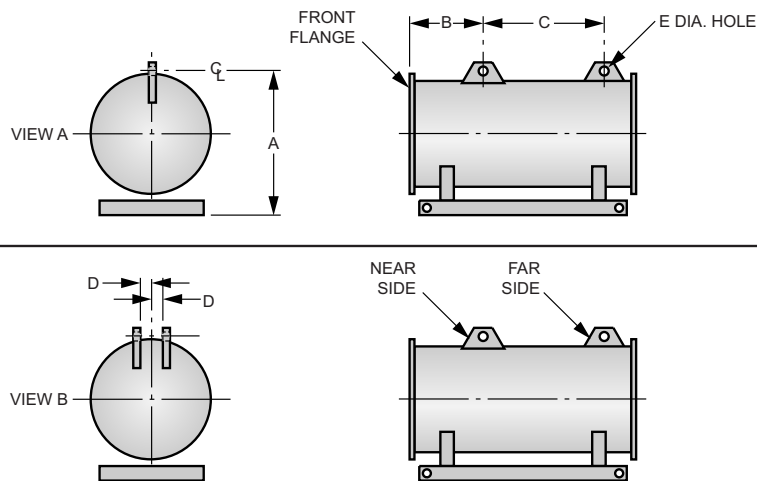

Table 19. CBEX Elite boiler mounting piers

BOILER HP	ALL DIMENSIONS IN INCHES (refer to Figure 3)								
	A	B	C	D	E	F	G	X1	X2
100	6	9	130.5	34.5	52.5	4	39.5	15	11.5
125	6	9	137.5	34.5	52.5	4	39.5	15	11.5
150	6	9	140	39.5	57.5	4	44.5	13	11.5
200	6	9	159	39.5	57.5	4	44.5	13	11.5
250	6	9	186.125	38	56	4	43	16	8
300	6	9	194.125	38	56	4	43	16	8
350	6	12	208.5	48	72	4	56	18	11.5
400	6	12	217.5	48	72	4	56	18	11.5
500	6	12	219.5	41.5	65.5	6.5	47	16	11.5
600	6	12	234.5	41.5	65.5	6.5	47	16	11.5
700	6	12	243.5	49.5	73.5	6.5	55	15	12.5
800	6	12	250.5	49.5	73.5	6.5	55	15	12.5

NOTE:

6-inch high mounting piers recommended for use beneath the boiler base frame. The use of these piers provides increased inspection accessibility to the boiler and added height for washing down the area beneath the boiler.

Figure 3. Mounting Piers

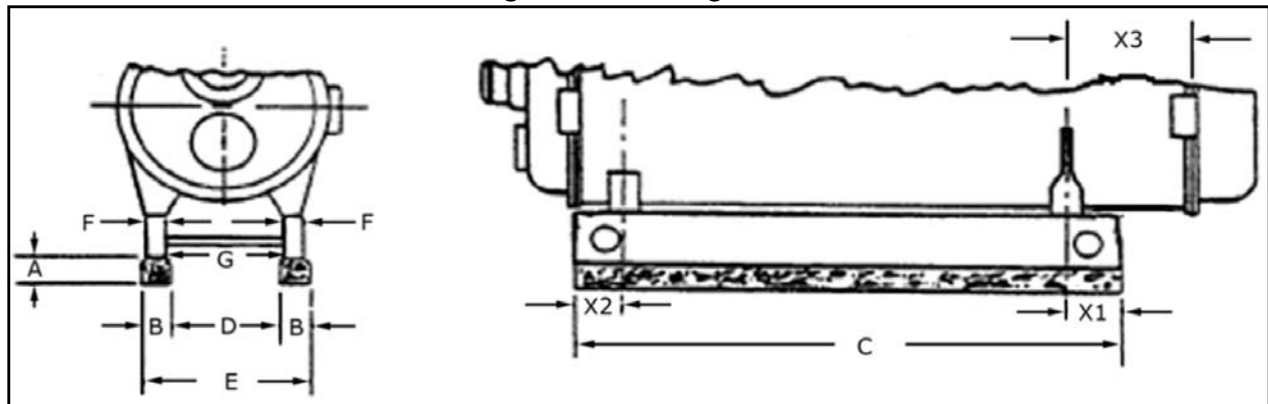
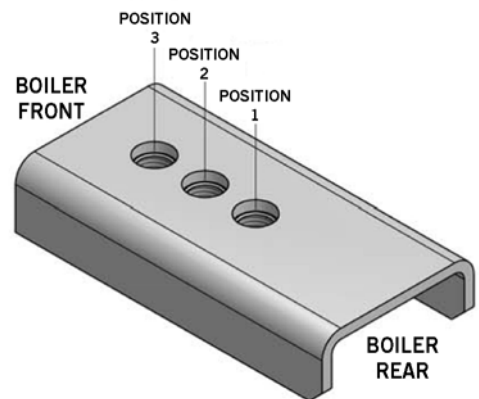

Table 20. Front Davit Support

Boiler HP	Motor HP	Hole Number
350-400	15	1
	25	2
500-600	15-25	1
	40	2
700-800	40	2
	60	3



Stack/Breeching Size Criteria

The design of the stack and breeching must provide the required draft at each boiler flue gas outlet. Proper draft is critical to burner performance.

Although constant pressure at the flue gas outlet of the CBEX is not required, it is necessary to size the stack/breeching to limit flue gas pressure variation. The allowable pressure range is -0.50" W.C. to +0.50" W.C. The maximum pressure variation at any firing rate for the boiler is 0.50" W.C.

The low NOx option allowable pressure range is -0.25" W.C. to +0.25" W.C. The maximum pressure variation

at any firing rate for the boiler is 0.25"W.C.

Stack and breeching sizes should always be provided by a reputable stack supplier who will design the stack and breeching system based on the above criteria. Your local Cleaver-Brooks authorized representative is capable of assisting in your evaluation of the stack/breeching design.

Figure 4. Stack & Breeching, Multiple Boilers

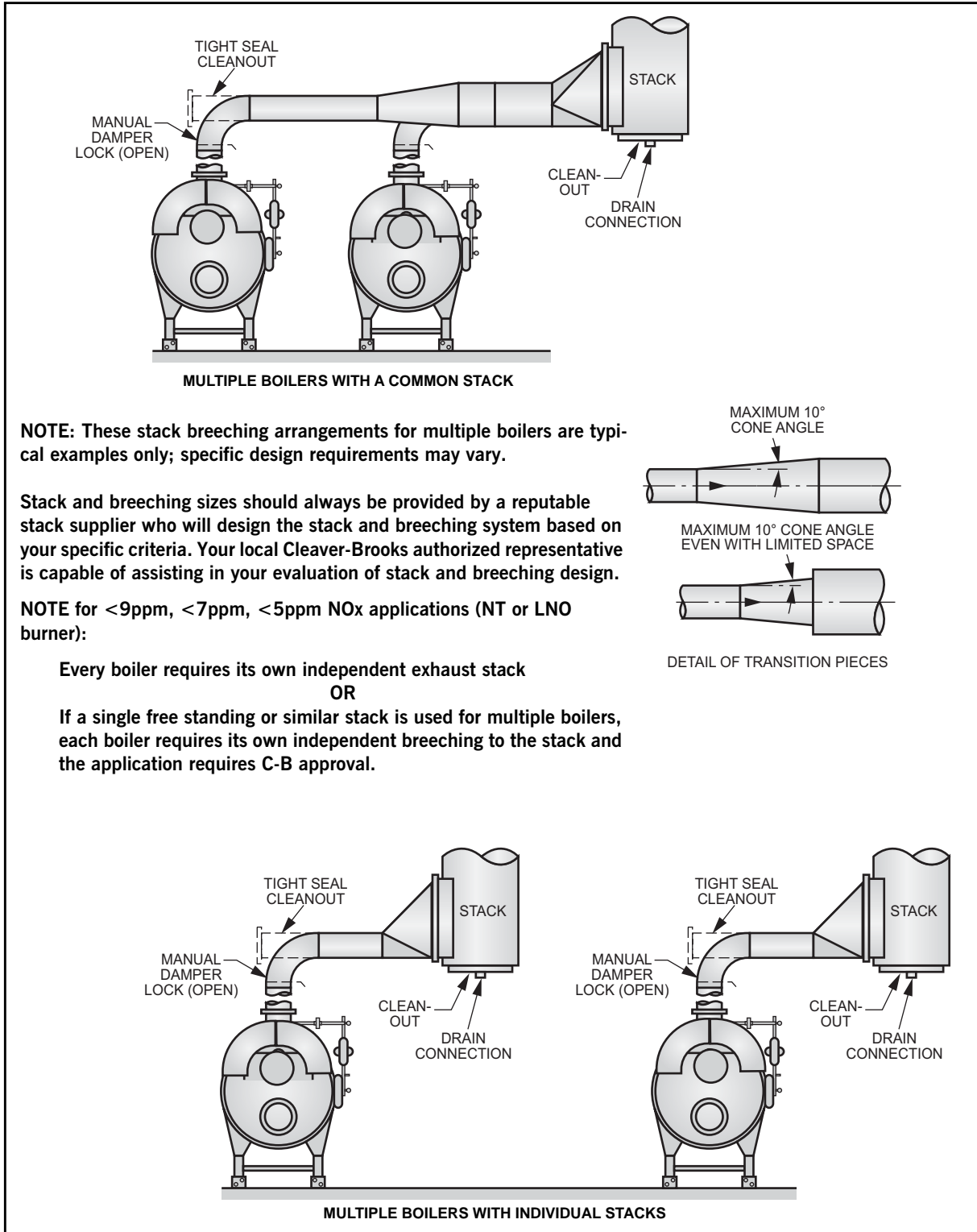



e-mail: info@cleaverbrooks.com
Web Address: <http://www.cleaverbrooks.com>