

MODEL ICB

100-800 HP



Boiler Book
03/2018



TABLE OF CONTENTS

FEATURES AND BENEFITS3
 PRODUCT OFFERING3
 DIMENSIONS AND RATINGS4
 PERFORMANCE DATA18
 ENGINEERING DATA18

ILLUSTRATIONS

Model ICB Steam Boiler Dimensions, 4-Pass and 3-Pass (Optional)9
 Model ICB Hot Water Boiler Dimensions, 4-Pass and 3-Pass (Optional)11
 Model ICB-LE Steam Boiler Dimensions, 4-Pass and 3-Pass (Optional)13
 Model ICB-LE Hot Water Boiler Dimensions, 4-Pass and 3-Pass (Optional)15
 Space Required to Open Rear Head on Model ICB Boilers17
 Model ICB Boilers Lifting Lug Location17
 Model ICB Boiler Mounting Piers18
 Typical Fuel Oil Supply Arrangement27
 Boiler Room Length (Typical Layouts) — Model ICB28
 Boiler Room Width (Typical Layout) — Model ICB28

TABLES

Model ICB Steam Boiler Ratings, 4-Pass5
 Model ICB Steam Boiler Ratings, 3-Pass5
 Model ICB Hot Water Boiler Ratings, 4-Pass6
 Model ICB Hot Water Boiler Ratings, 3-Pass6
 Model ICB-LE Steam Boiler Ratings, 4 Pass7
 Model ICB-LE Steam Boiler Ratings, 3 Pass7
 Model ICB-LE Hot Water Ratings, 4 Pass8
 Model ICB-LE Hot Water Ratings, 3 Pass8
 Model ICB Steam Boiler Dimensions, 4-Pass and 3-Pass10
 Model ICB Hot Water Boiler Dimensions, 4-Pass and 3-Pass12
 Model ICB-LE Steam Boiler Dimensions, 4-Pass and 3-Pass14
 Model ICB-LE Hot Water Boiler Dimensions, 4-Pass and 3-Pass16
 Model ICB Steam Volume and Disengaging Area21
 Model ICB Steam Boiler Safety Valve Outlet Size22
 Model ICB Hot Water Boiler Relief Valve Outlet Size22
 Model ICB Recommended Steam Nozzle Size23
 Model ICB Recommended Non-Return Valve Size23
 Model ICB Blowdown Tank Sizing Information24
 Altitude Correction for Gas24
 Sound Levels in dBA for 4-Pass ICB Boilers at High Fire24
 Minimum required gas pressure25
 Low NOx, minimum required gas pressure26

FEATURES AND BENEFITS

The Cleaver-Brooks Model ICB Boiler line provides a quality product utilizing a baseline boiler/burner design. Additionally, the boiler/burner package is UL compliant. The following features apply:

Four-Pass Intercooled Design:

Four-pass design provides high flue gas velocities and low stack temperatures to maximize efficiency.

Three-Pass Intercooled Design (optional):

Versatile design offered with choice of three or four-pass construction to meet application needs.

Intercooled Rear Turnaround:

Rear furnace turnaround area is fluid cooled and has a davited access opening for full accessibility to 2nd pass tubes and furnace. It eliminates confined space issues and provides for ease of maintenance. All tubes can be removed from either the front or rear of the boiler.

Front and Rear Doors:

- Davit, front and rear doors, all sizes.
- Provides access to front and rear tube sheet.
- Rear door completely covers and insulates rear tube sheet.

Natural Gas, No. 2 Oil, or Combination Burners Available:

- Combination gas/oil burners provide quick fuel changeover without burner adjustment.
- Ultra low NO_x emissions (<9ppm), consult factory.

PRODUCT OFFERING

Cleaver-Brooks Model ICB Boilers are available in low pressure steam, high pressure steam, and hot water designs. Burners are available to fire natural gas, No. 2 oil, or a combination of oil and gas. Standard product offering is:

- 100 – 800 hp.
- 30 and 125 psig hot water.
- 15 – 300 psig steam.
- Full modulation, all sizes.

Available options include the following (contact your local Cleaver-Brooks Authorized Representative for option details).

- Boiler Options:
 - Three-pass design.
 - Drain valves.
 - Additional screwed or flanged tappings.
 - Blowdown valves.
 - Non-return valves.
 - Feedwater valves and regulators.
 - Surface blowdown systems.
 - Blend pump.
 - Surge load baffles.
 - Seismic design.

- Burner/Control Options:
 - Flame safeguard controllers.
 - Lead/lag system.
 - High altitude design.
 - Special insurance and code requirements (e.g., IRI, FM, CSD-1).
 - Alarm bell/silence switch.
 - Special motor requirements (TEFC, high efficiency).
 - Special indicating lights.
 - Elapsed time meter.
 - Voltmeter/micro-ammeter.
 - NEMA enclosures.
 - Low-fire hold control.
 - Remote emergency shut-off (115V).
 - Circuit breakers.
 - Day/night controls.
 - Special power requirements.
 - Stack thermometer.
- Fuel Options
 - Air atomizing oil burner, 200 – 800 hp.
 - Pressure atomizing oil burner, 100 – 150 hp.
 - Gas strainer.
 - Gas pressure gauge.
 - Future gas conversion.
 - Oversized/undersized gas trains.

DIMENSIONS AND RATINGS

Dimensions and ratings for the Model ICB Boilers are shown in the following tables and illustrations. The information is subject to change without notice.

Table 1: Model ICB Steam Boiler Ratings, 4-Pass

BOILER H.P.	100	125	150	200	250	300	350	400	500	600	700	800
BURNER MODEL Model ICB	FP-3	FP-3	FP-3	FP-4	FP-4	D145P	D175P	D210P	D252P	D300P	D336P	D378P
RATINGS — SEA LEVEL TO 700 FT.												
Rated Capacity (lbs-steam/hr. from and at 212°F)	3450	4313	5175	6900	8625	10350	12075	13800	17250	20700	24150	27600
Btu Output (1000 Btu/hr.)	3348	4184	5021	6695	8369	10043	11716	13390	16738	20085	23433	26780
APPROXIMATE FUEL CONSUMPTION AT RATED CAPACITY BASED ON NOMINAL 82% EFFICIENCY												
Light Oil gph (140,000 Btu/gal)	29.2	36.4	43.7	58.3	72.9	87.5	102.1	116.6	145.8	175.0	204.1	233.3
Gas CFH (1000 Btu)	4082	5103	6123	8165	10206	12247	14288	16329	20412	24494	28576	32659
Gas (Therm/hr.)	40.8	51.0	61.2	81.6	102.1	122.5	142.9	163.3	204.1	244.9	285.8	326.6
POWER REQUIREMENTS — SEA LEVEL TO 700 FT. (60 HZ)												
Blower Motor hp	3	5	7-1/2	7-1/2	7-1/2	15	20	25	30	40	60	75
Separate Compressor Motor hp (Oil only)	**	**	**	3	3	—	7-1/2	7-1/2	7-1/2	7-1/2	7-1/2	15
Integral Oil/Air Motor hp (Oil only)	—	—	—	—	—	2	—	—	—	—	—	—
Oil Metering Pump Motor hp (Oil only)	—	—	—	—	—	—	1/2	3/4	3/4	3/4	3/4	1
Circulating Oil Pump Motor hp (Oil only)	1/3*	3/4*	3/4*	1/2	1/2	3/4	3/4	3/4	3/4	3/4	1	1
BOILER DATA												
Heating Surface sq.-ft. (Fireside)	353	438	555	729	885	1055	1384	1522	1734	2094	3244	3641

* = Base rail mounted oil pump will be 3-phase voltage

** = No air compressor required (pressure atomized system)

NOTE: All fractional hp motors will be single phase voltage except oil metering pump motor (3-phase); integral motors will be 3-phase voltage.

Table 2: Model ICB Steam Boiler Ratings, 3-Pass

BOILER H.P.	100	125	150	200	250	300	350	400	500	600	700	800
BURNER MODEL Model ICB	FP-3	FP-3	FP-3	FP-4	FP-4	FP-4	FP-4	D175P	D210P	D252P	D300P	D336P
RATINGS — SEA LEVEL TO 700 FT.												
Rated Capacity (lbs-steam/hr. from and at 212°F)	3450	4313	5175	6900	8625	10350	12075	13800	17250	20700	24150	27600
Btu Output (1000 Btu/hr.)	3348	4184	5021	6695	8369	10043	11716	13390	16738	20085	23433	26780
APPROXIMATE FUEL CONSUMPTION AT RATED CAPACITY BASED ON NOMINAL 80% EFFICIENCY												
Light Oil gph (140,000 Btu/gal)	29.9	37.4	44.8	59.8	74.7	89.7	104.6	119.6	149.4	179.3	209.2	239.1
Gas CFH (1000 Btu)	4184	5230	6277	8369	10461	12553	14645	16738	20922	25106	29291	33475
Gas (Therm/hr.)	41.8	52.3	62.8	83.7	104.6	125.5	146.5	167.4	209.2	251.1	292.9	334.8
POWER REQUIREMENTS — SEA LEVEL TO 700 FT. (60 HZ)												
Blower Motor hp	2	3	5	7-1/2	7-1/2	10	10	20	25	30	40	60
Separate Compressor Motor hp (Oil only)	**	**	**	3	3	3	3	5	5	7-1/2	7-1/2	7-1/2
Integral Oil/Air Motor hp (Oil only)	—	—	—	—	—	—	—	—	—	—	—	—
Oil Metering Pump Motor hp (Oil only)	—	—	—	—	—	—	—	1/2	3/4	3/4	3/4	3/4
Circulating Oil Pump Motor hp (Oil only)	1/3*	3/4*	3/4*	1/2	1/2	3/4	3/4	3/4	3/4	3/4	1	1
BOILER DATA												
Heating Surface sq.-ft. (Fireside)	353	438	555	729	885	1055	1384	1522	1734	2094	3244	3641

* = Base rail mounted oil pump will be 3-phase voltage

** = No air compressor required (pressure atomized system)

NOTE: All fractional hp motors will be single phase voltage except oil metering pump motor (3-phase); integral motors will be 3-phase voltage.

Table 3: Model ICB Hot Water Boiler Ratings, 4-Pass

BOILER H.P.	100	125	150	200	250	300	350	400	500	600	700	800
BURNER MODEL Model ICB	FP-3	FP-3	FP-3	FP-4	FP-4	D145P	D175P	D210P	D252P	D300P	D336P	D378P
RATINGS — SEA LEVEL TO 700 FT.												
Btu Output (1000 Btu/hr.)	3348	4184	5021	6695	8369	10043	11716	13390	16738	20085	23433	26780
APPROXIMATE FUEL CONSUMPTION AT RATED CAPACITY BASED ON NOMINAL 82% EFFICIENCY												
Light Oil gph (140,000 Btu/gal)	29.2	36.4	43.7	58.3	72.9	87.5	102.1	116.6	145.8	175.0	204.1	233.3
Gas CFH (1000 Btu)	4082	5103	6123	8165	10206	12247	14288	16329	20412	24494	28576	32659
Gas (Therm/hr.)	40.8	51.0	61.2	81.6	102.1	122.5	142.9	163.3	204.1	244.9	285.8	326.6
POWER REQUIREMENTS — SEA LEVEL TO 700 FT. (60 HZ)												
Blower Motor hp	3	5	7-1/2	7-1/2	7-1/2	15	20	25	30	40	60	75
Separate Compressor Motor hp (Oil only)	**	**	**	3	3	—	7-1/2	7-1/2	7-1/2	7-1/2	7-1/2	15
Integral Oil/Air Motor hp (Oil only)	—	—	—	—	—	2	—	—	—	—	—	—
Oil Metering Pump Motor hp (Oil only)	—	—	—	—	—	—	1/2	3/4	3/4	3/4	3/4	1
Circulating Oil Pump Motor hp (Oil only)	1/3*	3/4*	3/4*	1/2	1/2	3/4	3/4	3/4	3/4	3/4	1	1
BOILER DATA												
Heating Surface sq.-ft. (Fireside)	353	438	555	729	885	1055	1384	1522	1734	2094	3244	3641

* = Base rail mounted oil pump will be 3-phase voltage

** = No air compressor required (pressure atomized system)

NOTE: All fractional hp motors will be single phase voltage except oil metering pump motor (3-phase); integral motors will be 3-phase voltage.

Table 4: Model ICB Hot Water Boiler Ratings, 3-Pass

BOILER H.P.	100	125	150	200	250	300	350	400	500	600	700	800
BURNER MODEL Model ICB	FP-3	FP-3	FP-3	FP-4	FP-4	FP-4	FP-4	D175P	D210P	D252P	D300P	D336P
RATINGS — SEA LEVEL TO 700 FT.												
Btu Output (1000 Btu/hr.)	3348	4184	5021	6695	8369	10043	11716	13390	16738	20085	23433	26780
APPROXIMATE FUEL CONSUMPTION AT RATED CAPACITY BASED ON NOMINAL 80% EFFICIENCY												
Light Oil gph (140,000 Btu/gal)	29.9	37.4	44.8	59.8	74.7	89.7	104.6	119.6	149.4	179.3	209.2	239.1
Gas CFH (1000 Btu)	4184	5230	6277	8369	10461	12553	14645	16738	20922	25106	29291	33475
Gas (Therm/hr.)	41.8	52.3	62.8	83.7	104.6	125.5	146.5	167.4	209.2	251.1	292.9	334.8
POWER REQUIREMENTS — SEA LEVEL TO 700 FT. (60 HZ)												
Blower Motor hp	2	3	5	7-1/2	7-1/2	10	10	20	25	30	40	60
Separate Compressor Motor hp (Oil only)	**	**	**	3	3	3	3	5	5	7-1/2	7-1/2	7-1/2
Integral Oil/Air Motor hp (Oil only)	—	—	—	—	—	—	—	—	—	—	—	—
Oil Metering Pump Motor hp (Oil only)	—	—	—	—	—	—	—	1/2	3/4	3/4	3/4	3/4
Circulating Oil Pump Motor hp (Oil only)	1/3*	3/4*	3/4*	1/2	1/2	3/4	3/4	3/4	3/4	3/4	1	1
BOILER DATA												
Heating Surface sq.-ft. (Fireside)	353	438	555	729	885	1055	1384	1522	1734	2094	3244	3641

* = Base rail mounted oil pump will be 3-phase voltage

** = No air compressor required (pressure atomized system)

NOTE: All fractional hp motors will be single phase voltage except oil metering pump motor (3-phase); integral motors will be 3-phase voltage.

Table 5: Model ICB-LE Steam Boiler Ratings, 4 Pass

BOILER H.P.	100	125	150	200	250	300	350	400	500	600	700	800
BURNER MODEL	LND54P	LND84P	LND105P	LND125P	LND145P	LND175P	LND210P	LND252P	LND300P	LND315P	LND378P	LND420P
RATINGS - SEA LEVEL TO 700 FT.												
Rated Capacity (lbs-steam/hr from and at 212 OF)	3450	4313	5175	6900	8625	10350	12075	13800	17250	20700	24150	27600
Btu Output (1000 Btu/hr)	3348	4184	5021	6695	8369	10043	11716	13390	16738	20085	23433	26780
APPROXIMATE FUEL CONSUMPTION AT RATED CAPACITY BASED ON NOMINAL 82% EFFICIENCY												
Light Oil gph (140,000 Btu/gal)	29.2	36.4	43.7	58.3	72.9	87.5	102.1	116.6	145.8	175.0	204.1	233.3
Gas CFH (1000 Btu)	4082	5103	6123	8165	10206	12247	14288	16329	20412	24494	28576	32659
Gas (Therm/hr)	40.8	51.0	61.2	81.6	102.1	122.5	142.9	163.3	204.1	244.9	285.8	326.6
POWER REQUIREMENTS - SEA LEVEL TO 700 FT. (60 HZ)												
Blower Motor hp	5	7 1/2	10	15	15	20	25	30	40	60	75	75
Separate Compressor Motor hp (Oil only)	-	-	-	-	-	5	5	7 1/2	7 1/2	7 1/2	15	15
Integral Oil/Air Motor hp (Oil only)	1	1	1	1	2	-	-	-	-	-	-	-
Oil Metering Pump Motor hp (Oil only)	-	-	-	-	-	1/2	3/4	3/4	3/4	3/4	1	1
Circulating Oil Pump Motor hp (Oil only)	1/2	1/2	1/2	1/2	1/2	3/4	3/4	3/4	3/4	3/4	1	1
BOILER DATA												
Heating Surface sq-ft. (Fireside)	353	438	555	729	885	1055	1384	1522	1734	2094	3244	3641

NOTE: All fractional hp motors will be single phase voltage except oil metering pump motor (3-phase); integral motors will be 3-phase voltage.

Table 6: Model ICB-LE Steam Boiler Ratings, 3 Pass

BOILER H.P.	100	125	150	200	250	300	350	400	500	600	700	800
BURNER MODEL	LND54P	LND63P	LND84P	LND105P	LND145S	LND145P	LND175P	LND210P	LND252P	LND300P	LND315P	LND378P
RATINGS - SEA LEVEL TO 700 FT.												
Rated Capacity (lbs-steam/hr from and at 212 OF)	3450	4313	5175	6900	8625	10350	12075	13800	17250	20700	24150	27600
Btu Output (1000 Btu/hr)	3348	4184	5021	6695	8369	10043	11716	13390	16738	20085	23433	26780
APPROXIMATE FUEL CONSUMPTION AT RATED CAPACITY BASED ON NOMINAL 80% EFFICIENCY												
Light Oil gph (140,000 Btu/gal)	29.9	37.4	44.8	59.8	74.7	89.7	104.6	119.6	149.4	179.3	209.2	239.1
Gas CFH (1000 Btu)	4184	5230	6277	8369	10461	12553	14645	16738	20922	25106	29291	33475
Gas (Therm/hr)	41.8	52.3	62.8	83.7	104.6	125.5	146.5	167.4	209.2	251.1	292.9	334.8
POWER REQUIREMENTS - SEA LEVEL TO 700 FT. (60 HZ)												
Blower Motor hp	5	5	7 1/2	10	15	15	20	25	30	40	60	75
Separate Compressor Motor hp (Oil only)	-	-	-	-	-	-	5	5	7 1/2	7 1/2	7 1/2	15
Integral Oil/Air Motor hp (Oil only)	1	1	1	1	2	2	-	-	-	-	-	-
Oil Metering Pump Motor hp (Oil only)	-	-	-	-	-	-	1/2	3/4	3/4	3/4	3/4	1
Circulating Oil Pump Motor hp (Oil only)	1/2	1/2	1/2	1/2	1/2	3/4	3/4	3/4	3/4	3/4	1	1
BOILER DATA												
Heating Surface sq-ft. (Fireside)	353	438	555	729	885	1055	1384	1522	1734	2094	3244	3641

NOTE: All fractional hp motors will be single phase voltage except oil metering pump motor (3-phase); integral motors will be 3-phase voltage.

Table 7: Model ICB-LE Hot Water Ratings, 4 Pass

BOILER H.P.	100	125	150	200	250	300	350	400	500	600	700	800
BURNER MODEL	LND54P	LND84P	LND105P	LND125P	LND145P	LND175P	LND210P	LND252P	LND300P	LND315P	LND378P	LND420P
RATINGS - SEA LEVEL TO 700 FT.												
Btu Output (1000 Btu/hr)	3348	4184	5021	6695	8369	10043	11716	13390	16738	20085	23433	26780
APPROXIMATE FUEL CONSUMPTION AT RATED CAPACITY BASED ON NOMINAL 82% EFFICIENCY												
Light Oil gph (140,000 Btu/gal)	29.2	36.4	43.7	58.3	72.9	87.5	102.1	116.6	145.8	175.0	204.1	233.3
Gas CFH (1000 Btu)	4082	5103	6123	8165	10206	12247	14288	16329	20412	24494	28576	32659
Gas (Therm/hr)	40.8	51.0	61.2	81.6	102.1	122.5	142.9	163.3	204.1	244.9	285.8	326.6
POWER REQUIREMENTS - SEA LEVEL TO 700 FT. (60 HZ)												
Blower Motor hp	5	7 1/2	10	15	15	20	25	30	40	60	75	75
Separate Compressor Motor hp (Oil only)	-	-	-	-	-	5	5	7 1/2	7 1/2	7 1/2	15	15
Integral Oil/Air Motor hp (Oil only)	1	1	1	1	2	-	-	-	-	-	-	-
Oil Metering Pump Motor hp (Oil only)	-	-	-	-	-	1/2	3/4	3/4	3/4	3/4	1	1
Circulating Oil Pump Motor hp (Oil only)	1/2	1/2	1/2	1/2	1/2	3/4	3/4	3/4	3/4	3/4	1	1
BOILER DATA												
Heating Surface sq-ft. (Fire side)	353	438	555	729	885	1055	1384	1522	1734	2094	3244	3641

NOTE: All fractional hp motors will be single phase voltage except oil metering pump motor (3-phase); integral motors will be 3-phase voltage.

Table 8: Model ICB-LE Hot Water Ratings, 3 Pass

BOILER H.P.	100	125	150	200	250	300	350	400	500	600	700	800
BURNER MODEL	LND54P	LND63P	LND84P	LND105P	LND145S	LND145P	LND175P	LND210P	LND252P	LND300P	LND315P	LND378P
RATINGS - SEA LEVEL TO 700 FT.												
Btu Output (1000 Btu/hr)	3348	4184	5021	6695	8369	10043	11716	13390	16738	20085	23433	26780
APPROXIMATE FUEL CONSUMPTION AT RATED CAPACITY BASED ON NOMINAL 80% EFFICIENCY												
Light Oil gph (140,000 Btu/gal)	29.9	37.4	44.8	59.8	74.7	89.7	104.6	119.6	149.4	179.3	209.2	239.1
Gas CFH (1000 Btu)	4184	5230	6277	8369	10461	12553	14645	16738	20922	25106	29291	33475
Gas (Therm/hr)	41.8	52.3	62.8	83.7	104.6	125.5	146.5	167.4	209.2	251.1	292.9	334.8
POWER REQUIREMENTS - SEA LEVEL TO 700 FT. (60 HZ)												
Blower Motor hp	5	5	7 1/2	10	15	15	20	25	30	40	60	75
Separate Compressor Motor hp (Oil only)	-	-	-	-	-	-	5	5	7 1/2	7 1/2	7 1/2	15
Integral Oil/Air Motor hp (Oil only)	1	1	1	1	2	2	-	-	-	-	-	-
Oil Metering Pump Motor hp (Oil only)	-	-	-	-	-	-	1/2	3/4	3/4	3/4	3/4	1
Circulating Oil Pump Motor hp (Oil only)	1/2	1/2	1/2	1/2	1/2	3/4	3/4	3/4	3/4	3/4	1	1
BOILER DATA												
Heating Surface sq-ft. (Fire side)	353	438	555	729	885	1055	1384	1522	1734	2094	3244	3641

NOTE: All fractional hp motors will be single phase voltage except oil metering pump motor (3-phase); integral motors will be 3-phase voltage.

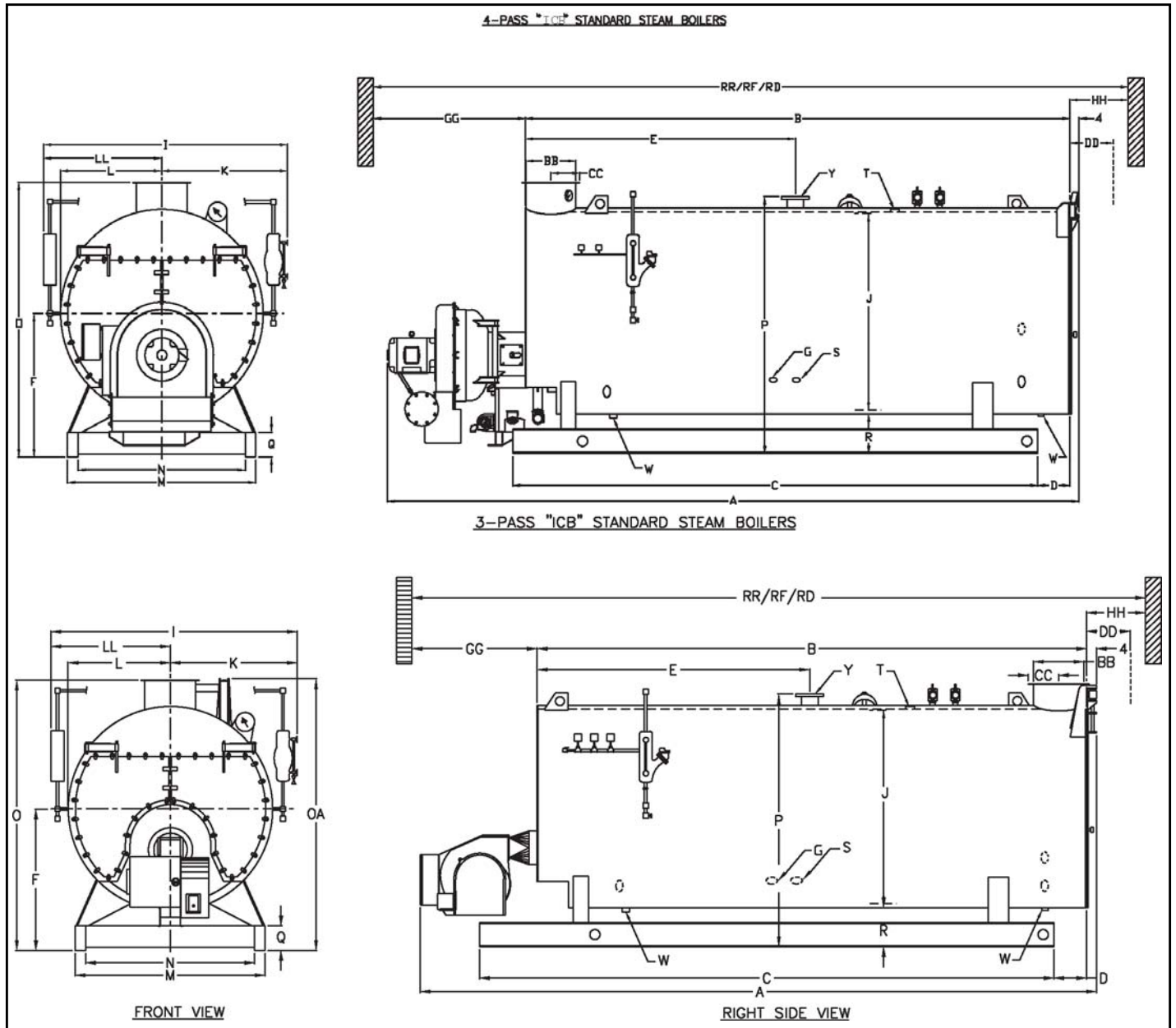

Figure 1. Model ICB Steam Boiler Dimensions, 4-Pass and 3-Pass (Optional)

Table 9: Model ICB Steam Boiler Dimensions, 4-Pass and 3-Pass

BOILER H.P.	DIM	100	125	150	200	250	300	350	400	500	600	700	800
LENGTHS													
Overall (3-Pass)	A	171"	197"	195"	243-1/2"	208-1/2"	234-1/2"	237-1/2"	263"	255"	290-1/2"	281-1/2"	306-1/2"
Overall (4-Pass)	A	171"	197"	195"	243-1/2"	208-1/2"	241"	247"	268"	257-1/2"	290-1/2"	284-1/2"	312"
Shell	B	127-7/8"	153-7/8"	151-7/8"	192-7/8"	160-7/8"	186-7/8"	189-7/8"	205-7/8"	195-3/4"	228-3/4"	219-7/8"	241-7/8"
Base Frame	C	124-3/8"	150-3/8"	148-3/8"	189-3/8"	157-3/8"	183-3/8"	184-3/8"	200-3/8"	187-1/4"	220-1/4"	211-3/8"	233-3/8"
Base Frame to Rear Flange	D	9-1/2"	9-1/2"	9-1/2"	9-1/2"	9-1/2"	9-1/2"	9-1/2"	9-1/2"	14-1/2"	14-1/2"	14-1/2"	14-1/2"
Flange to Steam Nozzle	E	55-7/8"	61-7/8"	65-7/8"	77-7/8"	68-7/8"	80-7/8"	78-7/8"	94-7/8"	82-3/4"	106-3/4"	98-7/8"	111-7/8"
WIDTHS													
Overall	I	80"	80"	85"	85"	97"	97"	103"	103"	117"	117"	131"	131"
I.D. Boiler	J	55"	55"	60"	60"	72"	72"	78"	78"	92"	92"	106"	106"
Center to Water Column	K	42-1/2"	42-1/2"	45"	45"	51"	51"	54"	54"	61"	61"	68"	68"
Center to Lagging	L	30-1/2"	30-1/2"	33"	33"	39"	39"	42"	42"	49"	49"	56"	56"
Center to Auxiliary LWCO	LL	37-1/2"	37-1/2"	40"	40"	46"	46"	49"	49"	56"	56"	63"	63"
Base Outside	M	47-1/2"	47-1/2"	52-1/2"	52-1/2"	58-1/2"	58-1/2"	64"	64"	68"	68"	74-3/4"	74-3/4"
Base Inside	N	39-1/2"	39-1/2"	44-1/2"	44-1/2"	50-1/2"	50-1/2"	56"	56"	55"	55"	61-3/4"	61-3/4"
HEIGHTS													
Base to Boiler Centerline	F	44-1/2"	44-1/2"	46"	46"	54"	54"	56"	56"	65-1/2"	65-1/2"	71"	71"
Base to Vent Outlet	O	80-3/4"	80-3/4"	85"	85"	101"	101"	106"	106"	122-1/2"	122-1/2"	135-5/8"	135-5/8"
Base to Rear Door Davit	OA	82-1/4"	82-1/4"	86-1/2"	86-1/2"	101"	101"	106"	106"	122-1/2"	122-1/2"	135-5/8"	135-5/8"
Base to Steam Outlet	P	78-3/8"	78-3/8"	82-3/8"	82-3/8"	96-1/4"	96-1/4"	101-1/2"	101-1/2"	118"	118"	130-5/8"	130-5/8"
Base Frame	Q	12"	12"	12"	12"	12"	12"	12"	12"	12"	12"	12"	12"
Base to Bottom Boiler	R	16"	16"	16"	16"	17"	17"	17"	17"	19"	19"	17-1/2"	17-1/2"
CONNECTIONS													
Chemical Feed	G	1"	1"	1"	1"	1"	1"	1"	1"	1"	1"	1"	1"
Feedwater Inlet (Both Sides)	S	1-1/4"	1-1/2"	1-1/2"	2"	2"	2"	2-1/2"	2-1/2"	2-1/2"	2-1/2"	2-1/2"	2-1/2"
Steam Nozzle (15 psig) ¹⁵⁰ LB. FLG.	Y	8"	8"	8"	10"	12"	12"	12"	12"	12"	12"	12"	12"
Steam Nozzle (150 psig) ³⁰⁰ LB. FLG.	Y	4"	4"	4"	4"	6"	6"	6"	6"	8"	8"	8"	8"
Drain — Front & Rear (15 psig)	W	1-1/2"	1-1/2"	1-1/2"	2"	2"	2"	2"	2"	2"	2"	2"	2"
Blowdown-Front & Rear(150 psig)	W	1-1/4"	1-1/2"	1-1/2"	1-1/2"	1-1/2"	1-1/2"	1-1/2"	2"	2"	2"	2"	2"
Surface Blowoff (150 psig only)	T	1"	1"	1"	1"	1"	1"	1"	1"	1"	1"	1"	1"
Vent Stack Diameter (Flanged)	BB	16"	16"	16"	16"	20"	20"	20"	20"	24"	24"	24"	24"
Flange to Center Vent	CC	9-1/8"	9-1/8"	9-1/8"	9-1/8"	10-5/8"	10-5/8"	10-5/8"	10-5/8"	12-5/8"	12-5/8"	12-5/8"	12-5/8"
MINIMUM CLEARANCES													
Rear Door Swing	DD	34"	34"	36"	36"	43"	43"	46"	46"	53"	53"	60"	60"
Tube Removal — Front	GG	95"	121"	119"	160"	122"	148"	149"	165"	146"	179"	170"	192"
Tube Removal — Rear	HH	96-1/2"	122-1/2"	120-1/2"	161-1/2"	126-1/2"	152-1/2"	150-1/2"	166-1/2"	148-1/2"	181-1/2"	172-1/2"	194-1/2"
MINIMUM BOILER ROOM LENGTH ALLOWING FOR DOOR SWING AND TUBE REMOVAL FROM:													
Front of Boiler	RF	257"	309"	307"	389"	326"	378"	385"	417"	395"	461"	450"	494"
Rear of Boiler (3-Pass)	RR	303-1/2"	355-1/2"	351-1/2"	441"	371"	423"	427"	468-1/2"	441-1/2"	510"	492"	539"
Rear of Boiler (4-Pass)	RR	303-1/2"	355-1/2"	351-1/2"	441"	371"	429-1/2"	436-1/2"	473-1/2"	444"	510"	495"	544-1/2"
Thru Window or Door (3-Pass)	RD	237"	263"	263"	311-1/2"	283-1/2"	309-1/2"	315-1/2"	341"	340"	375-1/2"	373-1/2"	398-1/2"
Thru Window or Door (4-Pass)	RD	237"	263"	263"	311-1/2"	283-1/2"	316"	325"	346"	342-1/2"	375-1/2"	376-1/2"	404"
WEIGHTS													
Normal Water Weight (lbs)	—	5,140	6,515	7,184	9,612	10,175	12,278	13,192	14,593	17,870	21,780	26,638	30,026
Shipping Weight — (15 psig) (lbs)	—	10,123	11,303	11,931	14,106	16,958	19,051	22,344	23,918	28,934	33,189	41,179	45,226
Shipping Weight — (150 psig) (lbs)	—	10,877	12,220	13,112	15,637	17,613	20,404	25,344	27,175	31,990	36,780	45,724	50,244
Shipping Weight — (200 psig) (lbs)	—	11,420	12,850	14,000	16,575	19,400	22,400	25,810	25,740	33,710	39,100	50,025	55,000

NOTE: Accompanying dimensions, while sufficiently accurate for layout purposes, must be confirmed for actual option requirements.

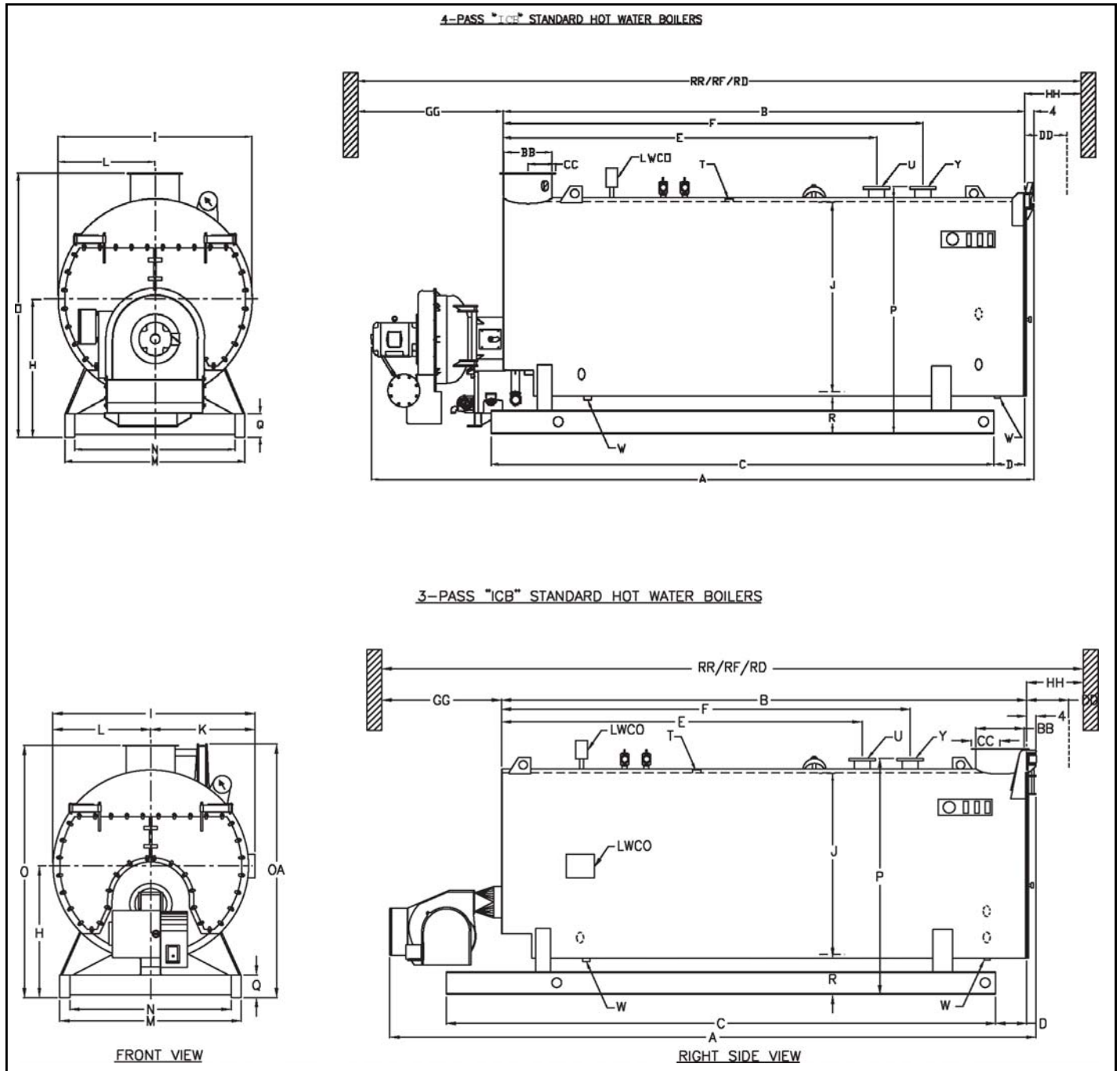

Figure 2. Model ICB Hot Water Boiler Dimensions, 4-Pass and 3-Pass (Optional)

Table 10: Model ICB Hot Water Boiler Dimensions, 4-Pass and 3-Pass

BOILER H.P.	DIM	100	125	150	200	250	300	350	400	500	600	700	800
LENGTHS													
Overall (3-Pass)	A	171"	197"	195"	243-1/2"	208-1/2"	234-1/2"	237-1/2"	263"	255"	290-1/2"	281-1/2"	306-1/2"
Overall (4-Pass)	A	171"	197"	195"	243-1/2"	208-1/2"	241"	247"	268"	257-1/2"	290-1/2"	284-1/2"	312"
Shell	B	127-7/8"	153-7/8"	151-7/8"	192-7/8"	160-7/8"	186-7/8"	189-7/8"	205-7/8"	195-3/4"	228-3/4"	219-7/8"	241-7/8"
Base Frame	C	124-3/8"	150-3/8"	148-3/8"	189-3/8"	157-3/8"	183-3/8"	184-3/8"	200-3/8"	187-1/4"	220-1/4"	211-3/8"	233-3/8"
Base Frame to Rear Flange	D	9-1/2"	9-1/2"	9-1/2"	9-1/2"	9-1/2"	9-1/2"	9-1/2"	9-1/2"	14-1/2"	14-1/2"	14-1/2"	14-1/2"
Flange to Return	E	82"	98"	95-5/8"	136-5/8"	101-5/8"	115-5/8"	117-5/8"	132-5/8"	125-1/2"	143-1/2"	139-1/2"	161-1/2"
Flange to Outlet	F	97-1/2"	123"	120-5/8"	161-5/8"	127-5/8"	141-5/8"	143-5/8"	158-5/8"	152-1/2"	175"	171"	193"
WIDTHS													
Overall	I	65"	65"	70"	70"	82"	82"	88"	88"	102"	102"	116"	116"
I.D. Boiler	J	55"	55"	60"	60"	72"	72"	78"	78"	92"	92"	106"	106"
Center to LWCO Controller	K	34-1/2"	34-1/2"	37"	37"	43"	43"	46"	46"	53"	53"	60"	60"
Base Outside	M	47-1/2"	47-1/2"	52-1/2"	52-1/2"	58-1/2"	58-1/2"	64"	64"	68"	68"	74-3/4"	74-3/4"
Base Inside	N	39-1/2"	39-1/2"	44-1/2"	44-1/2"	50-1/2"	50-1/2"	56"	56"	55"	55"	61-3/4"	61-3/4"
HEIGHTS													
Base to Boiler Centerline	H	44-1/2"	44-1/2"	46"	46"	54"	54"	56"	56"	65-1/2"	65-1/2"	71"	71"
Base to Vent Outlet	O	80-3/4"	80-3/4"	85"	85"	101"	101"	106"	106"	122-1/2"	122-1/2"	135-5/8"	135-5/8"
Base to Rear Door Davit	OA	82-1/4"	82-1/4"	86-1/2"	86-1/2"	101"	101"	106"	106"	122-1/2"	122-1/2"	135-5/8"	135-5/8"
Base to Return/Outlet	P	78-3/8"	78-3/8"	82-3/8"	82-3/8"	96-1/4"	96-1/4"	101-1/2"	101-1/2"	118"	118"	130-5/8"	130-5/8"
Base Frame	Q	12"	12"	12"	12"	12"	12"	12"	12"	12"	12"	12"	12"
Base to Bottom Boiler	R	16"	16"	16"	16"	17"	17"	17"	17"	19"	19"	17-1/2"	17-1/2"
CONNECTIONS													
Water Return (150 lb Flange)	U	4"	6"	6"	6"	8"	8"	8"	10"	10"	12"	12"	12"
Water Outlet (150 lb Flange)	Y	4"	6"	6"	6"	8"	8"	8"	10"	10"	12"	12"	12"
Drain — Front & Rear	W	1-1/2"	1-1/2"	1-1/2"	2"	2"	2"	2"	2"	2"	2"	2"	2"
Air Vent	T	1-1/4"	1-1/2"	1-1/2"	1-1/2"	1-1/2"	1-1/2"	1-1/2"	1-1/2"	2"	2"	2"	2"
Vent Stack Diameter (Flanged)	BB	16"	16"	16"	16"	20"	20"	20"	20"	24"	24"	24"	24"
Flange to Center Vent	CC	9-1/8"	9-1/8"	9-1/8"	9-1/8"	10-5/8"	10-5/8"	10-5/8"	10-5/8"	12-5/8"	12-5/8"	12-5/8"	12-5/8"
MINIMUM CLEARANCES													
Rear Door Swing	DD	34"	34"	36"	36"	43"	43"	46"	46"	53"	53"	60"	60"
Tube Removal — Front	GG	95"	121"	119"	160"	122"	148"	149"	165"	146"	179"	170"	192"
Tube Removal — Rear	HH	96-1/2"	122-1/2"	120-1/2"	161-1/2"	126-1/2"	152-1/2"	150-1/2"	166-1/2"	148-1/2"	181-1/2"	172-1/2"	194-1/2"
MINIMUM BOILER ROOM LENGTH ALLOWING FOR DOOR SWING AND TUBE REMOVAL FROM:													
Front of Boiler	RF	257"	309"	307"	389"	326"	378"	385"	417"	395"	461"	450"	494"
Rear of Boiler (3-Pass)	RR	303-1/2"	355-1/2"	351-1/2"	441"	371"	423"	427"	468-1/2"	441-1/2"	510"	492"	539"
Rear of Boiler (4-Pass)	RR	303-1/2"	355-1/2"	351-1/2"	441"	371"	429-1/2"	436-1/2"	473-1/2"	444"	510"	495"	544-1/2"
Thru Window or Door (3-Pass)	RD	237"	263"	263"	311-1/2"	283-1/2"	309-1/2"	315-1/2"	341"	340"	375-1/2"	373-1/2"	398-1/2"
Thru Window or Door (4-Pass)	RD	237"	263"	263"	311-1/2"	283-1/2"	316"	325"	346"	342-1/2"	375-1/2"	376-1/2"	404"
WEIGHTS													
Normal Water Weight (lbs)	—	5,848	7,397	8,378	11,180	11,940	14,380	16,190	17,884	22,572	27,431	32,991	37,120
Shipping Weight — (30psig) (lbs)	—	10,123	11,303	11,931	14,106	16,958	19,051	22,344	23,918	28,934	33,189	41,179	45,226
Shipping Weight — (125psig) (lbs)	—	10,238	11,418	13,153	15,679	18,609	21,270	24,522	26,631	32,175	36,972	47,122	51,782

NOTE: Accompanying dimensions, while sufficiently accurate for layout purposes, must be confirmed for actual option requirements.

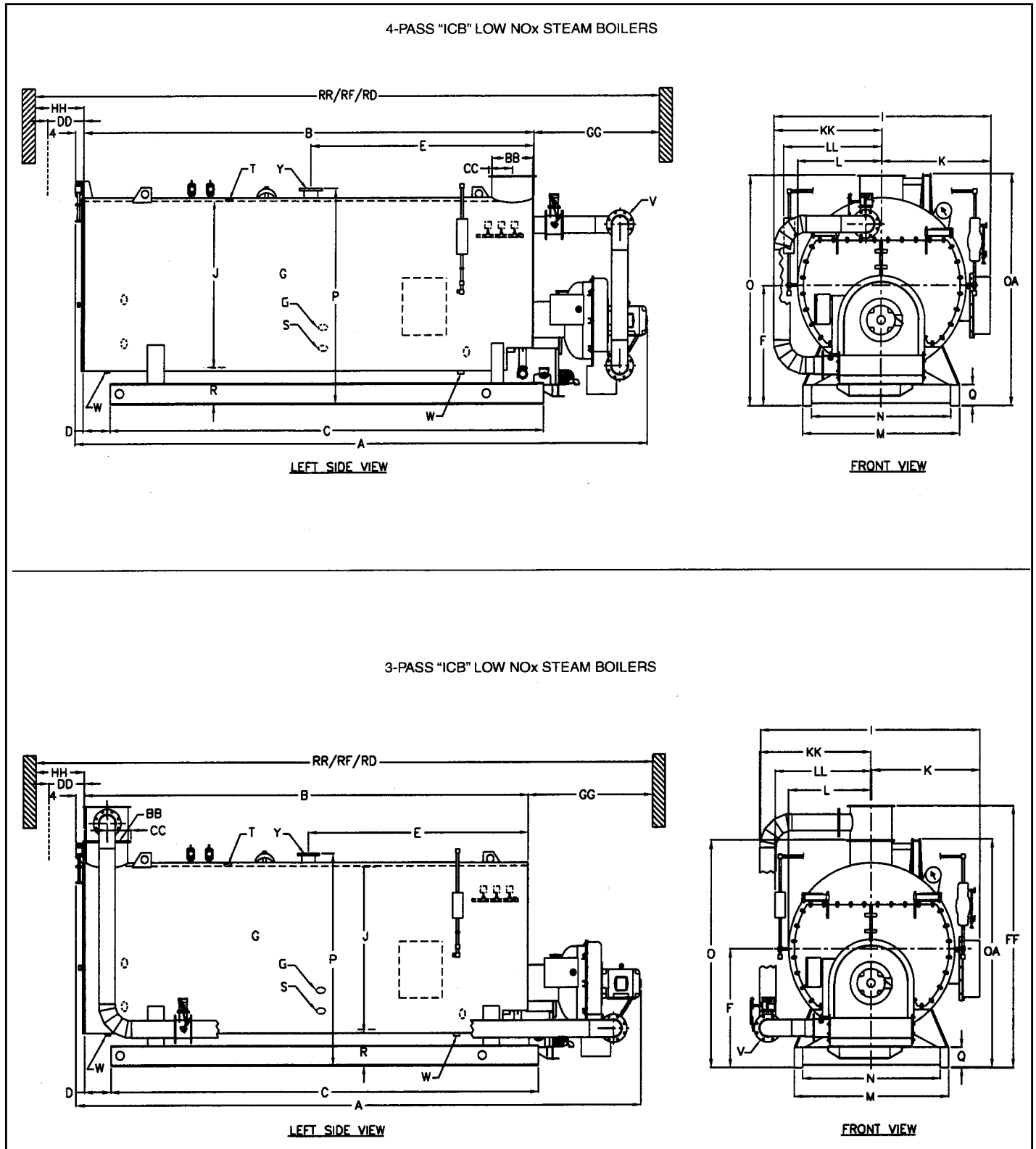

Table 11: Model ICB-LE Steam Boiler Dimensions, 4-Pass and 3-Pass

BOILER H.P.	DM	100	125	150	200	250	300	350	400	500	600	700	800
LENGTHS													
Overall (3-Pass)	A	173"	199"	199"	240"	215"	241"	247"	268"	257-1/2"	290-1/2"	285-1/2"	312"
Overall (4-Pass)	A	173"	201"	199"	240"	215"	244"	252"	270-1/2"	257-1/2"	293-1/2"	290"	312"
Shell	B	127-7/8"	153-7/8"	151-7/8"	192-7/8"	160-7/8"	186-7/8"	189-7/8"	205-7/8"	195-3/4"	228-3/4"	219-7/8"	241-7/8"
Base Frame	C	124-3/8"	150-3/8"	148-3/8"	189-3/8"	157-3/8"	183-3/8"	184-3/8"	200-3/8"	187-1/4"	220-1/4"	211-3/8"	233-3/8"
Base Frame to Rear Flange	D	9-1/2"	9-1/2"	9-1/2"	9-1/2"	9-1/2"	9-1/2"	9-1/2"	9-1/2"	14-1/2"	14-1/2"	14-1/2"	14-1/2"
Flange to Steam Nozzle	E	55-7/8"	61-7/8"	65-7/8"	77-7/8"	68-7/8"	80-7/8"	78-7/8"	94-7/8"	82-3/4"	106-3/4"	98-7/8"	111-7/8"
WIDTHS													
Overall (3-Pass)	I	87"	87"	92"	92"	104"	106"	112"	112"	126"	128"	142"	142"
Overall (4-Pass)	I	82"	82"	87"	87"	100"	100"	109"	109"	122"	122"	133"	133"
I.D. Boiler	J	55"	55"	60"	60"	72"	72"	78"	78"	92"	92"	106"	106"
Center to Water Column	K	44-1/2"	44-1/2"	47"	47"	53"	53"	56"	56"	63"	63"	70"	70"
Center to Outside FGR Pipe (3-Pass)	KK	42-1/2"	42-1/2"	45"	45"	51"	53"	56"	56"	63"	65"	72"	72"
Center to Outside FGR Pipe (4-Pass)	KK	37"	37"	37"	37"	47"	47"	53"	53"	59"	59"	59"	59"
FGR Duct Size (3-Pass)	V	6"	6"	6"	6"	6"	8"	8"	8"	8"	10"	10"	10"
FGR Duct Size (4-Pass)	V	6"	6"	6"	6"	6"	8"	8"	8"	10"	10"	10"	10"
Center to Lagging	L	30-1/2"	30-1/2"	33"	33"	39"	39"	42"	42"	49"	49"	56"	56"
Center to Auxiliary LWCO	LL	37-1/2"	37-1/2"	40"	40"	46"	46"	49"	49"	56"	56"	63"	63"
Base Outside	M	47-1/2"	47-1/2"	52-1/2"	52-1/2"	58-1/2"	58-1/2"	64"	64"	68"	68"	74-3/4"	74-3/4"
Base Inside	N	39-1/2"	39-1/2"	44-1/2"	44-1/2"	50-1/2"	50-1/2"	56"	56"	55"	55"	61-3/4"	61-3/4"
HEIGHTS													
Base to Boiler Centerline	F	44-1/2"	44-1/2"	46"	46"	54"	54"	56"	56"	65-1/2"	65-1/2"	71"	71"
Base to Vent Outlet	O	80-3/4"	80-3/4"	85"	85"	101"	101"	106"	106"	122-1/2"	122-1/2"	135-5/8"	135-5/8"
Base to Rear Door Davit	OA	82-1/4"	82-1/4"	86-1/2"	86-1/2"	101"	101"	106"	106"	122-1/2"	122-1/2"	135-5/8"	135-5/8"
Base to FGR Stack Extension (3-Pass Only)	FF	94-3/4"	94-3/4"	99"	99"	118"	118"	123"	123"	142-1/2"	142-1/2"	155-5/8"	155-5/8"
Base to Steam Outlet	P	78-3/8"	78-3/8"	82-3/8"	82-3/8"	96-1/4"	96-1/4"	101-1/2"	101-1/2"	118"	118"	130-5/8"	130-5/8"
Base Frame	Q	12"	12"	12"	12"	12"	12"	12"	12"	12"	12"	12"	12"
Base to Bottom Boiler	R	16"	16"	16"	16"	17"	17"	17"	17"	19"	19"	17-1/2"	17-1/2"
CONNECTIONS													
Chemical Feed	G	1"	1"	1"	1"	1"	1"	1"	1"	1"	1"	1"	1"
Feedwater Inlet (Both Sides)	S	1-1/4"	1-1/2"	1-1/2"	2"	2"	2"	2-1/2"	2-1/2"	2-1/2"	2-1/2"	2-1/2"	2-1/2"
Steam Nozzle (15 psig) ¹⁵⁰ LB. FLG.	Y	8"	8"	8"	10"	10"	12"	12"	12"	12"	12"	12"	12"
Steam Nozzle (150 psig) ³⁰⁰ LB. FLG.	Y	4"	4"	4"	4"	6"	6"	6"	6"	8"	8"	8"	8"
Drain — Front & Rear (15 psig)	W	1-1/2"	1-1/2"	1-1/2"	2"	2"	2"	2"	2"	2"	2"	2"	2"
Blowdown-Front & Rear (150 psig)	W	1-1/4"	1-1/2"	1-1/2"	1-1/2"	1-1/2"	1-1/2"	1-1/2"	2"	2"	2"	2"	2"
Surface Blowoff (150 psig only)	T	1"	1"	1"	1"	1"	1"	1"	1"	1"	1"	1"	1"
Vent Stack Diameter (Flanged)	BB	16"	16"	16"	16"	20"	20"	20"	20"	24"	24"	24"	24"
Flange to Center Vent	CC	9-1/8"	9-1/8"	9-1/8"	9-1/8"	10-5/8"	10-5/8"	10-5/8"	10-5/8"	12-5/8"	12-5/8"	12-5/8"	12-5/8"
MINIMUM CLEARANCES													
Rear Door Swing	DD	34"	34"	36"	36"	43"	43"	46"	46"	53"	53"	60"	60"
Tube Removal — Front	GG	95"	121"	119"	160"	122"	148"	149"	165"	146"	179"	170"	192"
Tube Removal — Rear	HH	96-1/2"	122-1/2"	120-1/2"	161-1/2"	126-1/2"	152-1/2"	150-1/2"	166-1/2"	148-1/2"	181-1/2"	172-1/2"	194-1/2"
MINIMUM BOILER ROOM LENGTH ALLOWING FOR DOOR SWING AND TUBE REMOVAL FROM:													
Front of Boiler	RF	257"	309"	307"	389"	326"	378"	385"	417"	395"	461"	450"	494"
Rear of Boiler (3-Pass)	RR	305-1/2"	357-1/2"	355-1/2"	437-1/2"	377-1/2"	429-1/2"	436-1/2"	473-1/2"	444"	510"	496"	544-1/2"
Rear of Boiler (4-Pass)	RR	305-1/2"	359-1/2"	355-1/2"	437-1/2"	377-1/2"	432-1/2"	441-1/2"	476"	444"	513"	500-1/2"	544-1/2"
Thru Window or Door (3-Pass)	RD	239"	265"	267"	308"	290"	316"	325"	346"	342-1/2"	375-1/2"	376-1/2"	404"
Thru Window or Door (4-Pass)	RD	239"	267"	267"	308"	290"	319"	330"	348-1/2"	342-1/2"	378-1/2"	382"	404"
WEIGHTS													
Normal Water Weight	—	5,140	6,515	7,184	9,612	10,175	12,278	13,192	14,593	17,870	21,780	26,638	30,026
Shipping Weight — (15psig)	—	10,123	11,303	11,931	14,106	16,958	19,051	22,344	23,918	28,934	33,189	41,179	45,226
Shipping Weight — (150psig)	—	10,877	12,220	13,112	15,637	17,613	20,404	25,344	27,175	31,990	36,780	45,724	50,244

NOTE: Accompanying dimensions, while sufficiently accurate for layout purposes, must be confirmed for actual option requirements.

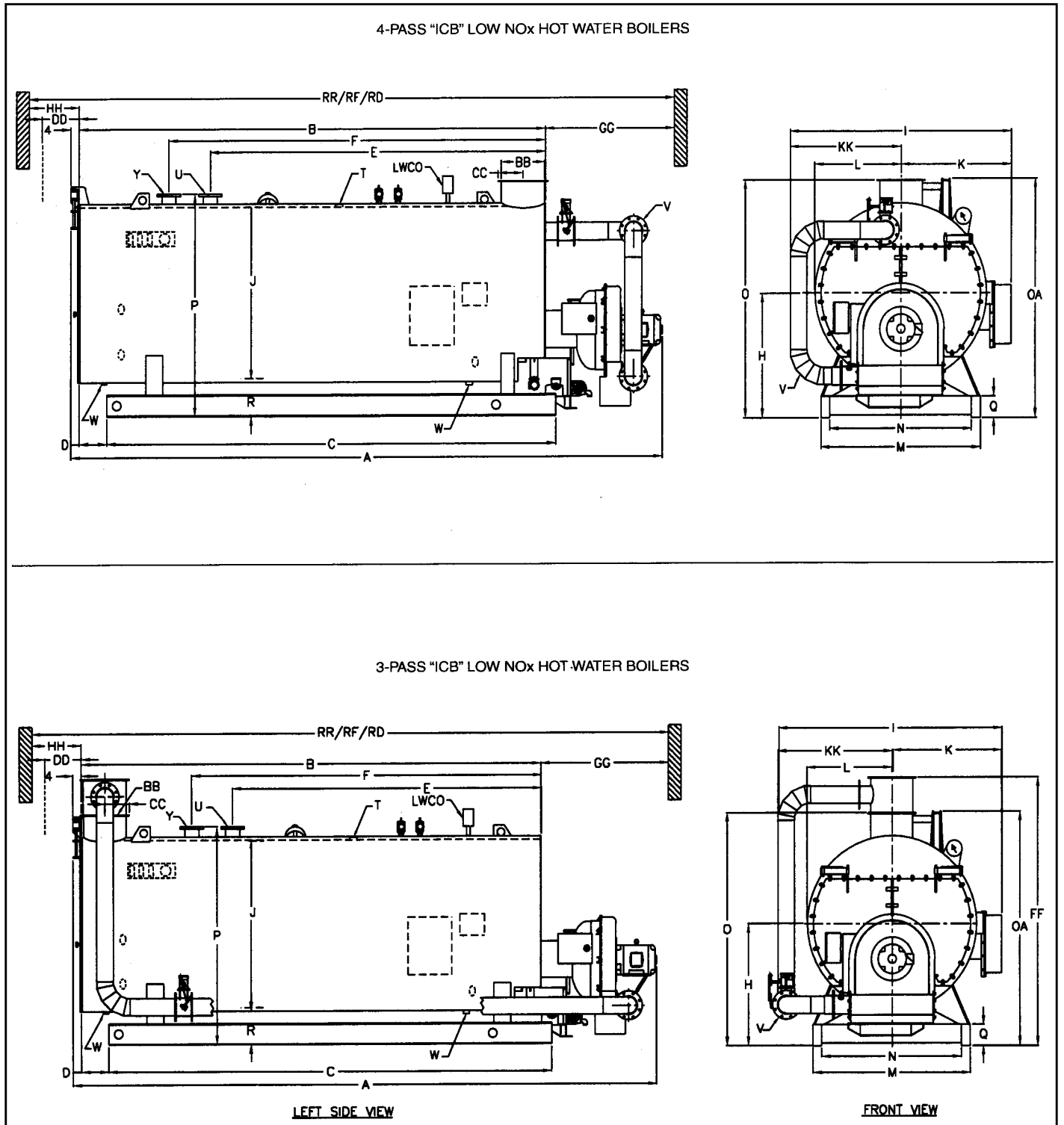

Figure 4. Model ICB-LE Hot Water Boiler Dimensions, 4-Pass and 3-Pass (Optional)

Table 12: Model ICB-LE Hot Water Boiler Dimensions, 4-Pass and 3-Pass

BOILER H.P.	DM	100	125	150	200	250	300	350	400	500	600	700	800
LENGTHS													
Overall (3-Pass)	A	173"	199"	199"	240"	215"	241"	247"	268"	257-1/2"	290-1/2"	285-1/2"	312"
Overall (4-Pass)	A	173"	201"	199"	240"	215"	244"	252"	270-1/2"	257-1/2"	293-1/2"	290"	312"
Shell	B	127-7/8"	153-7/8"	151-7/8"	192-7/8"	160-7/8"	186-7/8"	189-7/8"	205-7/8"	195-3/4"	228-3/4"	219-7/8"	241-7/8"
Base Frame	C	124-3/8"	150-3/8"	148-3/8"	189-3/8"	157-3/8"	183-3/8"	184-3/8"	200-3/8"	187-1/4"	220-1/4"	211-3/8"	233-3/8"
Base Frame to Rear Flange	D	9-1/2"	9-1/2"	9-1/2"	9-1/2"	9-1/2"	9-1/2"	9-1/2"	9-1/2"	14-1/2"	14-1/2"	14-1/2"	14-1/2"
Flange to Return	E	82"	98"	95-5/8"	136-5/8"	101-5/8"	115-5/8"	117-5/8"	132-5/8"	125-1/2"	143-1/2"	139-1/2"	161-1/2"
Flange to Outlet	F	97-1/2"	123"	120-5/8"	161-5/8"	127-5/8"	141-5/8"	143-5/8"	158-5/8"	152-1/2"	175"	171"	193"
WIDTHS													
Overall (3-Pass)	I	87"	87"	92"	92"	104"	106"	112"	112"	126"	128"	142"	142"
Overall (4-Pass)	I	81-1/2"	81-1/2"	84"	84"	100"	100"	109"	109"	122"	122"	129"	129"
L.D. Boiler	J	55"	55"	60"	60"	72"	72"	78"	78"	92"	92"	106"	106"
Center to Control Panel	K	44-1/2"	44-1/2"	47"	47"	53"	53"	56"	56"	63"	63"	70"	70"
Center to Outside FGR Pipe (3-Pass)	KK	42-1/2"	42-1/2"	45"	45"	51"	53"	56"	56"	63"	65"	72"	72"
Center to Outside FGR Pipe (4-Pass)	KK	37"	37"	37"	37"	47"	47"	53"	53"	59"	59"	59"	59"
FGR Duct Size (3-Pass)	V	6"	6"	6"	6"	6"	8"	8"	8"	8"	10"	10"	10"
FGR Duct Size (4-Pass)	V	6"	6"	6"	6"	6"	8"	8"	8"	8"	10"	10"	10"
Center to Lagging	L	30-1/2"	30-1/2"	33"	33"	39"	39"	42"	42"	49"	49"	56"	56"
Base Outside	M	47-1/2"	47-1/2"	52-1/2"	52-1/2"	58-1/2"	58-1/2"	64"	64"	68"	68"	74-3/4"	74-3/4"
Base Inside	N	39-1/2"	39-1/2"	44-1/2"	44-1/2"	50-1/2"	50-1/2"	56"	56"	55"	55"	61-3/4"	61-3/4"
HEIGHTS													
Base to Boiler Centerline	H	44-1/2"	44-1/2"	46"	46"	54"	54"	56"	56"	65-1/2"	65-1/2"	71"	71"
Base to Vent Outlet	O	80-3/4"	80-3/4"	85"	85"	101"	101"	106"	106"	122-1/2"	122-1/2"	135-5/8"	135-5/8"
Base to Rear Door Davit	OA	82-1/4"	82-1/4"	86-1/2"	86-1/2"	101"	101"	106"	106"	122-1/2"	122-1/2"	135-5/8"	135-5/8"
Base to FGR Stack Extension (3-Pass Only)	FF	94-3/4"	94-3/4"	99"	99"	118"	118"	123"	123"	142-1/2"	142-1/2"	155-5/8"	155-5/8"
Base to Return/Outlet	P	78-3/8"	78-3/8"	82-3/8"	82-3/8"	96-1/4"	96-1/4"	101-1/2"	101-1/2"	118"	118"	130-5/8"	130-5/8"
Base Frame	Q	12"	12"	12"	12"	12"	12"	12"	12"	12"	12"	12"	12"
Base to Bottom Boiler	R	16"	16"	16"	16"	17"	17"	17"	17"	19"	19"	17-1/2"	17-1/2"
CONNECTIONS													
Water Return (150 lb Flange)	U	4"	6"	6"	6"	8"	8"	8"	10"	10"	12"	12"	12"
Water Outlet (150 lb Flange)	Y	4"	6"	6"	6"	8"	8"	8"	10"	10"	12"	12"	12"
Drain — Front & Rear	W	1-1/2"	1-1/2"	1-1/2"	2"	2"	2"	2"	2"	2"	2"	2"	2"
Air Vent	T	1-1/4"	1-1/2"	1-1/2"	1-1/2"	1-1/2"	1-1/2"	1-1/2"	1-1/2"	2"	2"	2"	2"
Vent Stack Diameter (Flanged)	BB	16"	16"	16"	16"	20"	20"	20"	20"	24"	24"	24"	24"
Flange to Center Vent	CC	9-1/8"	9-1/8"	9-1/8"	9-1/8"	10-5/8"	10-5/8"	10-5/8"	10-5/8"	12-5/8"	12-5/8"	12-5/8"	12-5/8"
MINIMUM CLEARANCES													
Rear Door Swing	DD	34"	34"	36"	36"	43"	43"	46"	46"	53"	53"	60"	60"
Tube Removal — Front	GG	95"	121"	119"	160"	122"	148"	149"	165"	146"	179"	170"	192"
Tube Removal — Rear	HH	96-1/2"	122-1/2"	120-1/2"	161-1/2"	126-1/2"	152-1/2"	150-1/2"	166-1/2"	148-1/2"	181-1/2"	172-1/2"	194-1/2"
MINIMUM BOILER ROOM LENGTH ALLOWING FOR DOOR SWING AND TUBE REMOVAL FROM:													
Front of Boiler	RF	257"	309"	307"	389"	326"	378"	385"	417"	395"	461"	450"	494"
Rear of Boiler (3-Pass)	RR	305-1/2"	357-1/2"	355-1/2"	437-1/2"	377-1/2"	429-1/2"	436-1/2"	473-1/2"	444"	510"	496"	544-1/2"
Rear of Boiler (4-Pass)	RR	305-1/2"	359-1/2"	355-1/2"	437-1/2"	377-1/2"	432-1/2"	441-1/2"	476"	444"	513"	500-1/2"	544-1/2"
Thru Window or Door (3-Pass)	RD	239"	265"	267"	308"	290"	316"	325"	346"	342-1/2"	375-1/2"	376-1/2"	404"
Thru Window or Door (4-Pass)	RD	239"	267"	267"	308"	290"	319"	330"	348-1/2"	342-1/2"	378-1/2"	382"	404"
WEIGHTS													
Normal Water Weight (lbs)	—	5,848	7,397	8,378	11,180	11,940	14,380	16,190	17,884	22,572	27,431	32,991	37,120
Shipping Weight — (30psig) (lbs)	—	10,123	11,303	11,931	14,106	16,958	19,051	22,344	23,918	28,934	33,189	41,179	45,226
Shipping Weight — (125psig) (lbs)	—	10,238	11,418	13,153	15,679	18,609	21,270	24,522	26,631	32,175	36,972	47,122	51,782

NOTE: Accompanying dimensions, while sufficiently accurate for layout purposes, must be confirmed for actual option requirements.

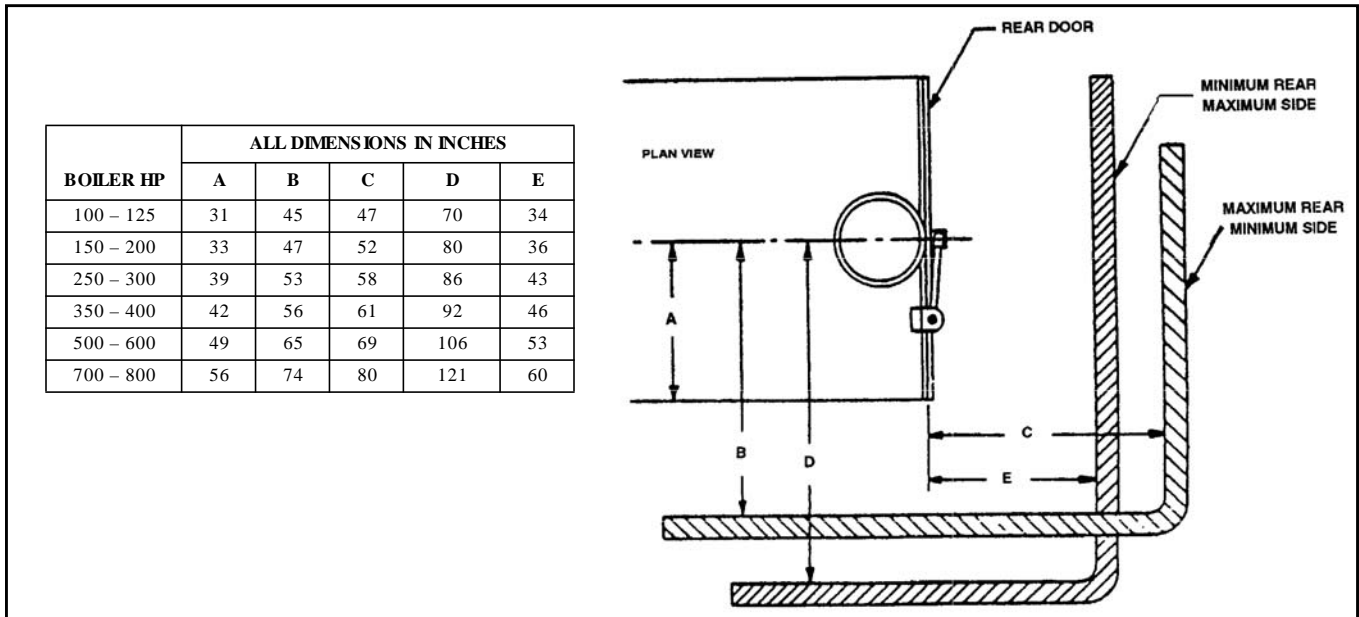

Figure 5. Space Required to Open Rear Head on Model ICB Boilers

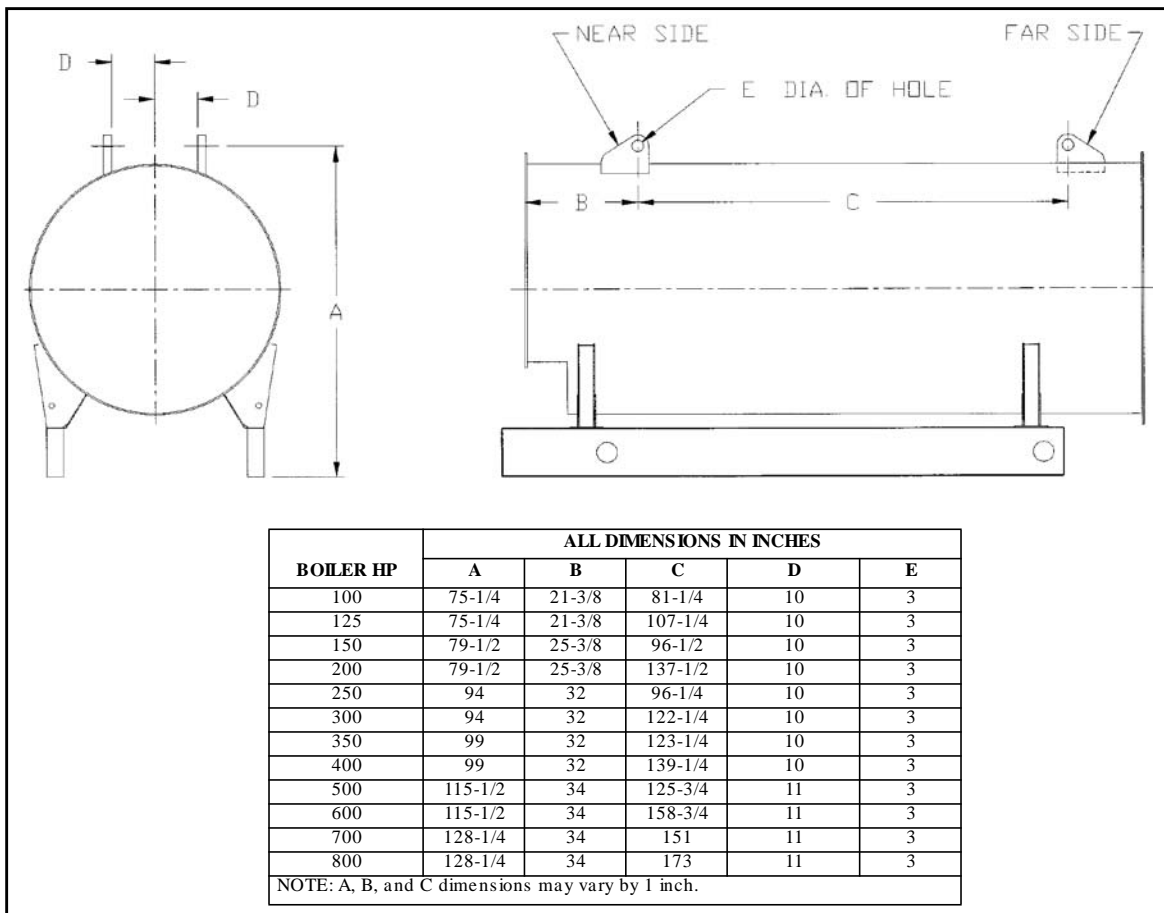

Figure 6. Model ICB Boilers Lifting Lug Location

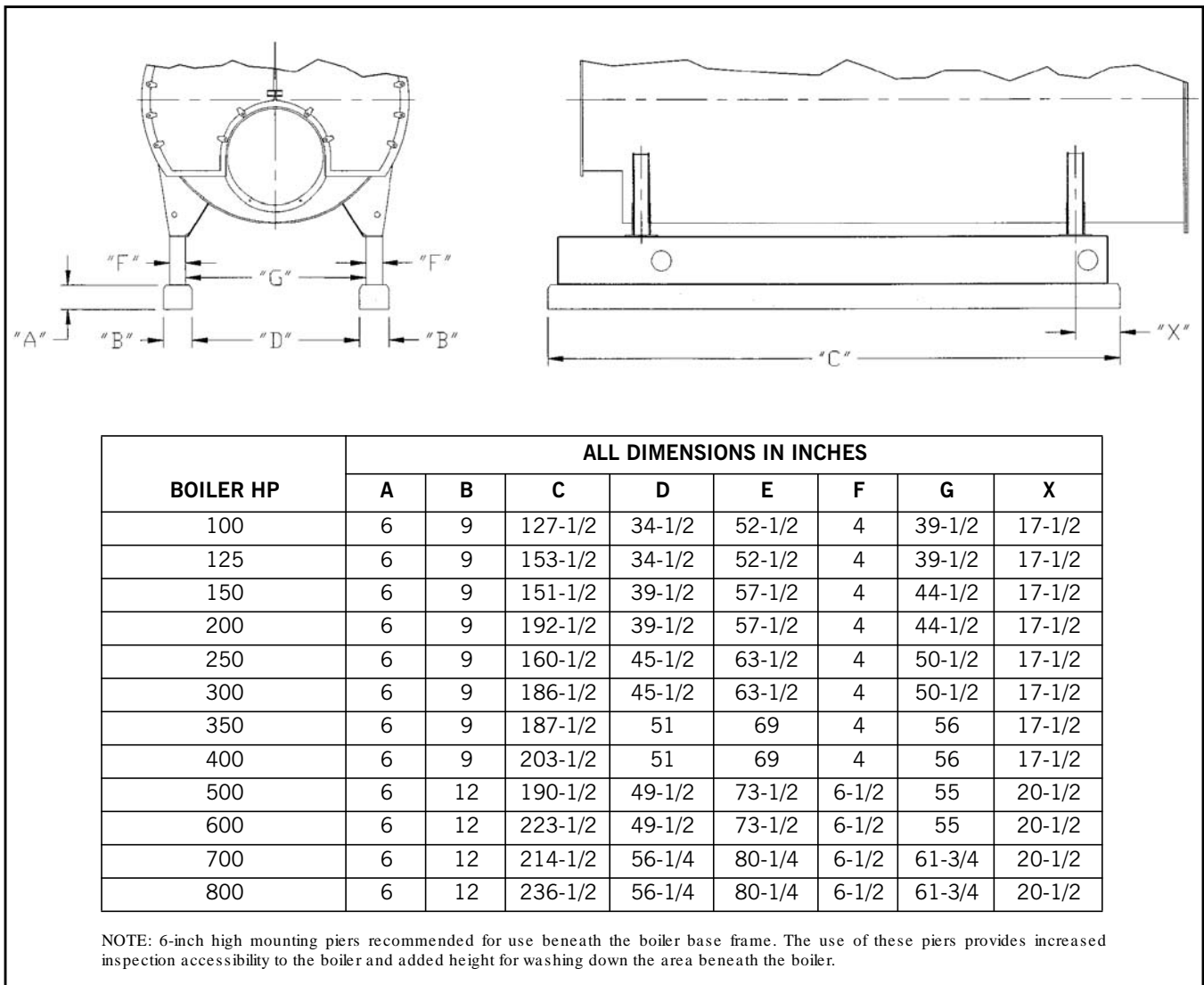

Figure 7. Model ICB Boiler Mounting Piers

PERFORMANCE DATA

Contact your local Cleaver-Brooks Authorized Representative for efficiencies or additional information.

Cleaver-Brooks ICB boilers are available with the standard burner package, or optional induced flue gas recirculation, refer to the Model ICB-LE for low NOx information.

ENGINEERING DATA

The following engineering information is provided for Model ICB Boilers. Additional detail is available from your local Cleaver-Brooks authorized representative.

Table A4-13 shows steam volume and disengaging area for Model ICB Boilers.

Table A4-14 lists quantity and outlet size for safety valves supplied on Model ICB Steam Boilers.

Table A4-15 lists quantity and outlet size for relief valves supplied on Model ICB Hot Water Boilers.

Table A4-16 gives recommended steam nozzle sizes on Model ICB Boilers.

Table A4-17 shows recommended non-return valve sizes for Model ICB Boilers.

Blowdown Water Requirements

Some local codes require blowdown tanks to be constructed in accordance with recommendations of the National Board of Boiler and Pressure Vessel Inspectors.

The National Board's recommendations base the size of the blowdown tank on the removal of at least 4 inches of water from the boiler.

Table A4-18 lists the approximate quantity of water represented by 4 inches of water at normal operating level for Cleaver-Brooks Model ICB Boilers.

Burner Characteristics

Maximum altitude for standard burners is 700 feet. Contact your local Cleaver-Brooks Authorized Representative for higher altitude availability. Note that altitude correction and burner changes are required for higher altitudes which may alter dimensions, motor hp and gas pressures.

Table A4-19 lists minimum required gas pressure for altitude correction.

Table A4-21 shows minimum and maximum gas pressure requirements for Standard, FM and IRI ICB Boiler gas trains upstream of the gas pressure regulator.

For oversized or undersized gas trains or altitude above 700 feet, contact your local Cleaver-Brooks Authorized Representative.

Fuel Connections — Gas

The local gas company should be consulted for requirements and authorization for installation and inspection of gas supply piping. Installation of gas supply piping and venting must be in accordance with all applicable engineering guidelines and regulatory codes. All connections made to the boiler should be arranged so that all components remain accessible for inspection, cleaning and maintenance.

A drip leg should be installed in the supply piping before the connection to the gas pressure regulator. The drip leg should be at least as large as the inlet fitting supplied with the boiler. Consideration must be given to both volume and pressure requirements when choosing gas supply piping size. Refer to the boiler dimension diagram provided by Cleaver-Brooks for the particular installation. Connections to the burner gas train should be made with a union, so that gas train components or the burner may be easily disconnected for inspection or service. Upon completion of the gas piping installation, the system should be checked for gas leakage and tight shutoff of all valves.

Fuel Connections — Oil

Oil-fired burners are equipped with an oil pump, which draws fuel from a storage tank and supplies pressurized oil to the burner nozzle(s). The burner supply oil pump has a greater capacity than the burner requires for the maximum firing rate. Fuel not delivered to the nozzle is returned to the storage tank. A two-pipe (supply and return) oil system is recommended for all installations. Figure 8 shows a typical fuel oil supply arrangement. Oil lines must be sized for the burner and burner supply oil pump capacities.

The burner supply oil pump suction should not exceed 10" Hg. If a transfer pump is used, it must have a pumping capacity at least equal to that of the burner pump(s). Supply pressure to the burner pump should not exceed 3 psig.

A strainer must be installed in the supply piping upstream of the burner supply pump in order to

prevent entry of foreign material into the pump, fuel control valves, or burner nozzle(s). The strainer must be sized for the burner supply pump capacity. A strainer mesh of 150 microns (0.005") is recommended.

Install a check valve in the line to prevent draining of the oil suction line when the burner is not in operation. Location of the check valve varies with the system, but usually it is located as close as possible to the storage tank.

Installation of a vacuum gauge in the burner supply line between the burner oil pump and the strainer is recommended. Regular observation and recording of the gauge indication will assist in determining when the strainer needs servicing.

Upon completion of the oil piping installation, the system should be checked for oil or air leakage and tight shutoff of all valves.

Boiler Room Information

Figure A4-9 shows typical boiler room length requirements.

Figure A4-10 shows typical boiler room width requirements.

Stack Support Capabilities

100 – 800 hp Model ICB Boilers can support up to 2000 lbs without additional support.

100 – 800 hp Model ICB Boilers can be reinforced to support up to 3000 lbs.

Boiler Room Combustion Air

When determining boiler room air requirements, the size of the room, air flow, and velocity of air must be reviewed as follows:

1. Size (area) and location of air supply openings in boiler room.
 - A. Two (2) permanent air supply openings in the outer walls of the boiler room are recommended. Locate one (1) at each end of the boiler room, preferably below a height of 7 feet. This allows air to sweep the length of the boiler.
 - B. Air supply openings can be louvered for weather protection, but they should not be covered with fine mesh wire, as this type of covering has poor air flow qualities and is subject to clogging by dust or dirt.
 - C. A vent fan in the boiler room is not recommended, as it could create a slight vacuum under certain conditions and cause variations in the quantity of combustion air. This can result in unsatisfactory burner performance. Under no condition should the total area of the air supply openings be less than one (1) square foot.
 - D. Size the openings by using the formula:

$$\text{Area (sq.-ft.)} = \text{CFM/FPM}$$

2. Amount of air required (cfm).
 - A. Combustion Air = Rated bhp x 8 cfm/bhp.
 - B. Ventilation Air = Maximum bhp x 2 cfm/bhp or a total of 10 cfm/bhp – up to 1000 feet elevation. Add 3 percent more per 1000 feet of added elevation.
3. Acceptable air velocity in Boiler Room (fpm).
 - A. From floor to (7) foot height – 250 fpm.
 - B. Above (7) foot height – 500 fpm.

Example: Determine the area of the boiler room air supply openings for (1) 300 hp boiler at 800 feet altitude. The air openings are to be 5 feet above floor level.

- Air required: $300 \times 10 = 3000$ cfm (from 2B above).

- Air velocity: Up to 7 feet = 250 fpm (from 3 above).
- Area Required: Area = cfm/fpm = 3000/250 = 12 sq.-ft. total.
- Area/Opening: 12/2 = 6 sq.-ft./opening (2 required).

Consult local codes, which may supersede these requirements.

Stack/Breeching Size Criteria

The design of the stack and breeching must provide the required draft at each boiler flue gas outlet. Proper draft is critical to burner performance.

Although constant pressure at the flue gas outlet of the Model ICB is not required, it is necessary to size the stack/breeching to limit flue gas pressure variation. The allowable pressure range is -0.25" W.C. to +0.25" W.C.

For additional information, please review Section I4, General Engineering Data (Stacks) and Section F, Stacks. Stack and breeching sizes should always be provided by a reputable stack supplier who will design the stack and breeching system based on the above criteria. Your local Cleaver-Brooks Authorized Representative is capable of assisting in your evaluation of the stack/breeching design.

Table 13: Model ICB Steam Volume and Disengaging Area

BOILER HP	STEAM VOLUME CU-FT.		STEAM RELIEVING AREA SQ.-IN	
	HIGH PRESSURE (A)	LOW PRESSURE (B)	HIGH PRESSURE (A)	LOW PRESSURE (B)
100	11.2	16.5	3917	4363
125	14	20.5	4882	5443
150	19	26.3	5472	5990
200	25	34.6	7200	7891
250	27.8	41.4	6811	7618
300	33.2	49.4	8122	9072
350	47.9	66.3	9374	10238
400	52.6	72.9	10296	11246
500	74.5	94.9	11405	12168
600	89.6	114.2	13723	14630
700	100.8	127	14602	15538
800	112.7	142	16315	17381

NOTE:

1. Based on normal water level.
- A. Based on 150 psig design pressure.
- B. Based on 15 psig design pressure.

Table 14: Model ICB Steam Boiler Safety Valve Outlet Size

VALVE SETTING	15 PSIG STEAM		150 PSIG STEAM		200 PSIG STEAM		250 PSIG STEAM	
BOILER HP	NO. OF VALVES REQ'D	OUTLET SIZE (IN.)	NO. OF VALVES REQ'D	OUTLET SIZE (IN.)	NO. OF VALVES REQ'D	OUTLET SIZE (IN.)	NO. OF VALVES REQ'D	OUTLET SIZE (IN.)
100	1	2-1/2	1	1-1/2	1	1-1/2	1	1-1/4
125	1	2-1/2	1	2	1	1-1/2	1	1 1/2
150	1	3	2	(1) 1-1/2 (1) 1-1/4	2	(1) 1-1/4 (1) 1	2	1
200	1	3	2	1-1/2	2	(1) 1-1/2 (1) 1-1/4	2	1-1/4
250	2	(2) 2-1/2	2	(1) 2 (1) 1-1/2	2	(1) 1-1/2 (1) 1-1/4	2	(1) 1-1/2 (1) 1-1/4
300	2	(1) 2-1/2 (1) 3	2	(1) 2 (1) 1-1/2	2	1-1/2	2	(1) 1-1/2 (1) 1-1/4
350	2	(2) 3	2	2	2	(1) 2 (1) 1-1/2	2	1-1/2
400	2	3	2	(1) 2-1/2 (1) 2	2	(1) 2 (1) 1-1/2	2	(1) 2 (1) 1-1/2
500	3	(2) 3 (1) 2-1/2	2	(1) 2-1/2 (1) 2	2	(1) 2 (1) 2-1/2	2	(1) 2 (1) 1-1/2
600	3	(3) 3	2	2-1/2	2	(1) 2 (1) 2-1/2	2	2
700	4	(3) 3 (1) 2-1/2	3	(2) 2-1/2 (1) 2	2	2-1/2	2	(1) 2-1/2 (1) 2
800	4	3	3	(2) 2-1/2 (1) 2	2	2-1/2	2	(1) 2-1/2 (1) 2

NOTE: Valve manufacturers are Kunkle, Consolidated or Conbraco, depending on availability. This table revised 03/2018.

Table 15: Model ICB Hot Water Boiler Relief Valve Outlet Size

VALVE SETTING	30 PSIG HW		125 PSIG HW		150 PSIG HW	
BOILER HP	NO. OF VALVES REQ'D	OUTLET SIZE (IN.)	NO. OF VALVES REQ'D	OUTLET SIZE (IN.)	NO. OF VALVES REQ'D	OUTLET SIZE (IN.)
100	1	2	1	1-1/4	1	2
125	1	2-1/2	1	1-1/4	2	1-1/2
150	1	2-1/2	1	1-1/4	2	(1) 1-1/2 (1) 2
200	2	2	1	2	2	2
250	2	(1) 1-1/2 (1) 2-1/2	1	2	2	(1) 2 (1) 2-1/2
300	2	(1) 2 (1) 2-1/2	1	2	2	(1) 2 (1) 2-1/2
350	2	2-1/2	1	2-1/2	2	2-1/2
400	3	(2) 2 (1) 2-1/2	1	2-1/2	2	(1) 2 (1) 3
500	3	(1) 2 (2) 2-1/2	1	2-1/2	2	(1) 2-1/2 (1) 3
600	3	2-1/2	2	(1) 1 (1) 2-1/2	2	3
700	4	(1) 2 (3) 2-1/2	2	(1) 1 (1) 2-1/2	3	(2) 3 (1) 2-1/2
800	4	2-1/2	2	(1) 2 (1) 2-1/2	3	3

NOTE: Relief valve is Kunkle #537 for 30# & 125#(Section IV) boiler and is Kunkle #927 for 150# HTHW (Section I) boiler.

Table 16: Model ICB Recommended Steam Nozzle Size

OPERATING PRESSURE PSIG	BOILER HP											
	100	125	150	200	250	300	350	400	500	600	700	800
15	8	8	8	10	10	12	12	12	12	12	12	12
30	6	6	6	8	8	8	10	10	10	12	12	12
40	6	6	6	6	8	8	8	10	10	10	12	12
50	4	6	6	6	6	8	8	8	10	10	10	12
75	4	4	4	6	6	6	8	8	8	8	10	10
100	4	4	4	6	6	6	6	6	8	8	8	10
125	4	4	4	4	6	6	6	6	8	8	8	8
150	2.5	3	3	4	4	6	6	6	6	6	8	8
200	2.5	2.5	3	4	4	4	4	6	6	6	6	6
250	2	2.5	3	3	4	4	4	4	6	6	6	6

NOTES:

1. Steam nozzle sizes given in inches.
2. Recommended steam nozzle sizes based on 4000 to 5000 fpm steam velocity.
3. All standard steam nozzle sizes for 150 psig design pressure or greater are the same as 125 psig operating pressure on the above table. To increase or decrease the standard size, request the change with your local Cleaver-Brooks authorized representative.
4. Shaded area denotes special surge load baffles must be installed to avoid possible water carryover.

Table 17: Model ICB Recommended Non-Return Valve Size

BOILER HP	BOILER CAPACITY (LBS/HR)	OPERATING PRESSURE (PSIG)							
		50	75	100	125	150	175	200	250
100	3450	2-1/2	2-1/2	NA	NA	NA	NA	NA	NA
125	4313	3	2-1/2	2-1/2	2-1/2	NA	NA	NA	NA
150	5175	3	3	2-1/2	2-1/2	2-1/2	2-1/2	NA	NA
200	6900	3*	3	3	3	3	2-1/2	2-1/2	2-1/2
250	8625	4	3*	3	3	3	3	3	3
300	10350	4	4	4	3*	3	3	3	3
350	12025	4	4	4	4	4	3*	3	3
400	13800	5	4	4	4	4	4	4	3*
500	17210	6	5	5	4	4	4	4	4
600	20700	6	6	5	5	5	4	4	4
700	24150	6	6	6	5	5	5	5	4
800	27600	6	6	6	6	6	5	5	5

NOTE:

Valve sizes (300# flanges) given in inches).
 Standard non-return valve selections limited to a maximum 2 to 1 turndown (50% of full boiler output); selection based on typical valve sizing recommendations. For final valve selection contact your authorized C-B representative.
 *Indicates pressure drop of less than 7.5 psig. All other selections are less than 6 psig pressure drop.

Table 18: Model ICB Blowdown Tank Sizing Information

BOILER HP	WATER (GAL)
100	75
125	94
150	102
200	135
250	125
300	150
350	174
400	191
500	206
600	248
700	266
800	297

NOTE: Quantity of water removed from boiler by lowering normal water line 4"

Table 19: Altitude Correction for Gas

ALTITUDE (FT.)	CORRECTION FACTOR	ALTITUDE (FT.)	CORRECTION FACTOR
1000	1.04	6000	1.25
2000	1.07	7000	1.3
3000	1.11	8000	1.35
4000	1.16	9000	1.4
5000	1.21	—	—

NOTE: To obtain minimum required gas pressure at altitudes above 700 feet, multiply the pressure by the listed factors:
 Inches WC x 0.577 = oz/sq.-in.
 oz/sq.-in x 1.732 = Inches WC.
 Inches WC x 0.0361 = psig.
 oz/sq.-in x 0.0625 = psig.
 psig x 27.71 = Inches WC.
 psig x 16.0 = oz/sq.-in.

Table 20: Sound Levels in dBA for 4-Pass ICB Boilers at High Fire

BHP	Sound Level — dBA
	ICB
100	80.0
125	84.5
150	84.5
200	84.5
250	84.5
300	91.0
350	94.0
400	91.5
500	93.5
600	93.5
700	93.7
800	93.7

Table 21: Model ICB, standard emissions, minimum required gas pressure at entrance to standard, FM & IRI gas trains (upstream of gas pressure regulator)

BOILER HP	STD PIPE SIZE (Inches)	PRESSURE REQUIRED, 3-PASS ("WC)			PRESSURE REQUIRED, 4-PASS ("WC)		
		GPR*	Minimum	Maximum	GPR*	Minimum	Maximum
100	2	RV91	8.5	27.7	RV91	10.5	27.7
125	2	RV91	13.5	27.7	RV91	16	27.7
150	2	RV91	17	27.7	RV91	21	27.7
200	2-1/2	RV111	20	27.7	210G	26	277
250	2-1/2	210G	32.5	277	210G	33	277
300	2-1/2	210G	45	277	210G	45.5	277
350	3	210G	46	277	210G	46.5	277
400	1.5-2	S	133	208	S	133	208
	2-2.5	S	91	133	S	94	133
	2.5	S	64	91	S	66	94
	3	S	39	64	S	42	66
500	1.5-2.5	S	191	277	S	183	277
	2-2.5	S	139	191	S	133	183
	2.5	S	94	139	S	89	133
	3	S	55	94	S	53	89
600	2-1.5-2.5	S	249	277	S	244	277
	2-2.5	S	191	249	S	188	244
	2.5	S	130	191	S	133	188
	2.5-3	S	108	130	S	111	133
	3	S	66	108	S	72	111
700	2-3	S	233	277	S	230	277
	2.5-3	S	141	233	S	141	230
	3	S	91	141	S	91	141
	4	S	58	91	S	64	91
800	2.5-3	S	177	277	S	175	277
	3	S	114	177	S	114	175
	4	S	72	114	S	72	114

NOTE: Where multiple gas train sizes are shown, the shaded row indicates standard size. For altitudes above 700 feet, contact your local Cleaver-Brooks authorized representative.

* GPR Gas Pressure Regulator

S-Siemens regulating actuator.

Table 22: Model ICB, low NOx, minimum required gas pressure at entrance to standard, FM & IRI gas trains (upstream of gas pressure regulator)

BOILER HP	STD PIPE SIZE (Inches)	PRESSURE REQUIRED, 3-PASS ("WC)			PRESSURE REQUIRED, 4-PASS ("WC)		
		GPR*	Minimum	Maximum	GPR*	Minimum	Maximum
100	2	RV91	13	27.7	RV91	15	27.7
125	2	RV91	19.5	27.7	RV91	17.5	27.7
150	2	RV91	20	27.7	RV91	21.5	27.7
200	2-1/2	210G	27	277	210G	32.5	277
250	2-1/2	210G	30	277	210G	35.5	277
300	2-1/2	210G	43	277	210G	47.5	277
350	3	210G	45	277	210G	49.5	277
400	1.5-2	S	133	208	S	133	208
	2	S	91	133	S	91	133
	2.5	S	66	91	S	66	91
	3	S	39	66	S	42	66
500	1.5-2.5	S	188	277	S	186	277
	2-2.5	S	136	188	S	136	186
	2.5	S	91	136	S	94	136
	3	S	53	91	S	55	94
600	2-1.5-2.5	S	252	277	S	247	277
	2-2.5	S	194	252	S	191	247
	2.5	S	130	194	S	133	191
	2.5-3	S	108	130	S	111	133
	3	S	69	108	S	75	111
700	2-3	S	235	277	S	230	277
	2.5-3	S	144	235	S	141	230
	3	S	91	144	S	91	141
	4	S	61	91	S	61	91
800	2.5-3	S	175	277	S	175	277
	3	S	111	175	S	114	175
	4	S	69	111	S	3	114

NOTE: Where multiple gas train sizes are shown, the shaded row indicates standard size. For altitudes above 700 feet, contact your local Cleaver-Brooks authorized representative.

* GPR Gas Pressure Regulator

S-Siemens regulating actuator.

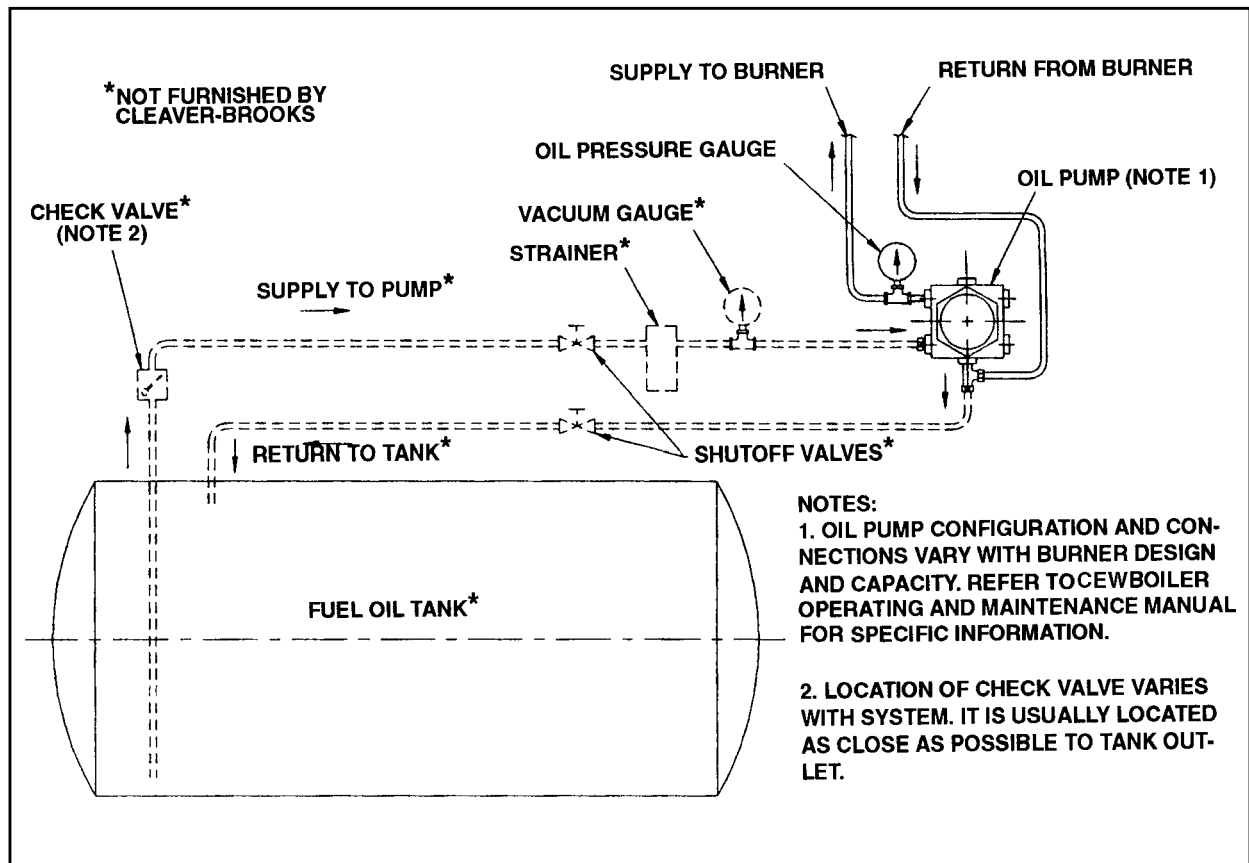

Figure 8. Typical Fuel Oil Supply Arrangement

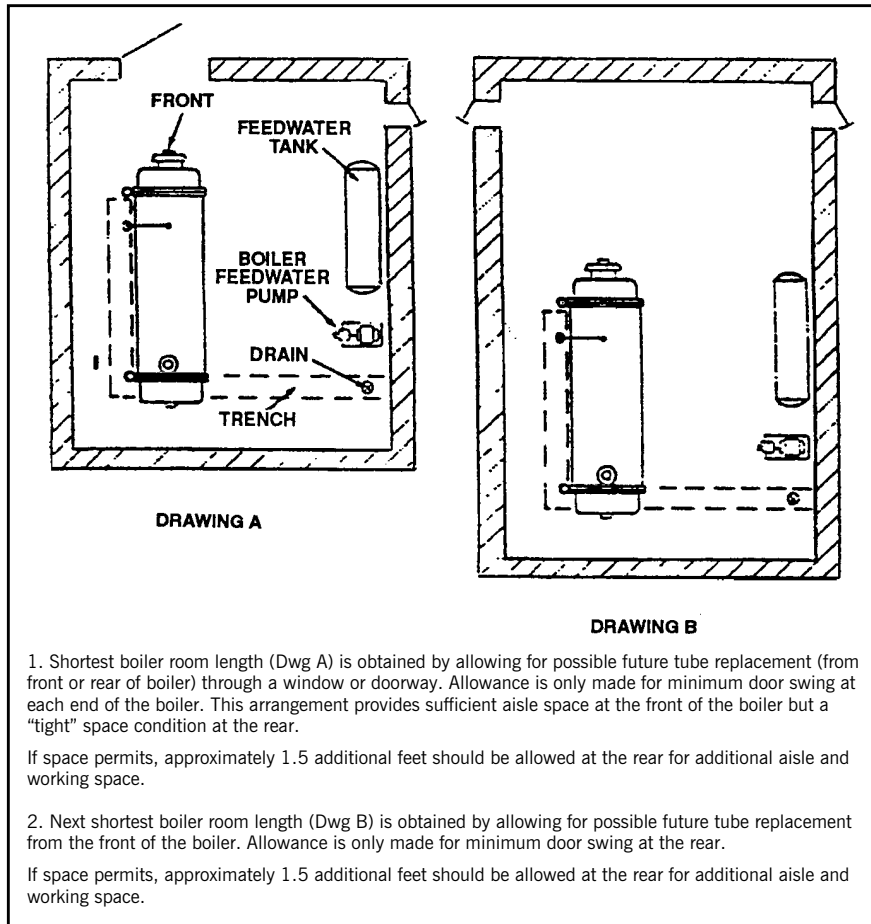

Figure 9. Boiler Room Length (Typical Layouts) — Model ICB

BOILER HP	100 – 125	150 – 200	250 – 300	350 – 400	500 – 600	700 – 800
DIM. "A"	84-1/2	87	93	96	103	110
DIM. "B"	115-1/2	120	138	144	170	184

NOTES:

1. Recommended Minimum Distance Between Boiler and Wall.
Dimension "A" allows for a clear 42" aisle between the water column on the boiler and the wall. If space permits, this aisle should be widened.
2. Recommended Minimum Distance Between Boilers.
Dimension "B" between boilers allows for a clear aisle of:
42" – 100-200 hp
48" – 250-400 hp
60" – 500-800 hp

If space permits, this aisle should be widened.

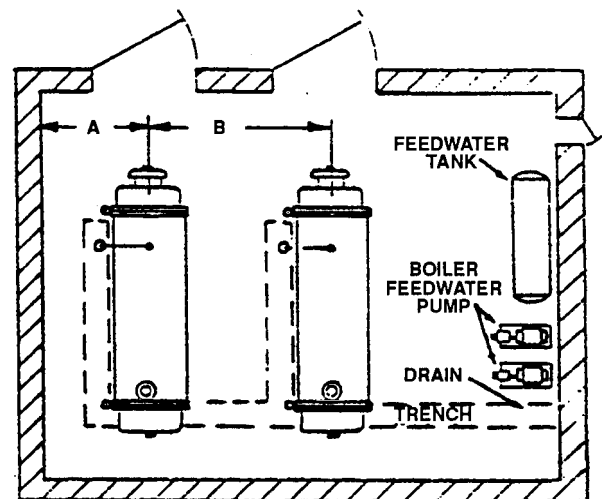

Figure 10. Boiler Room Width (Typical Layout) — Model ICB

