

ITEM	MAJOR COMPONENTS
1	CONTROL PANEL W/FALCON (120/1/60)
2	BLOWER MOTOR, 115V 50/60HZ
3	1" GAS TRAIN PIPING
4	VALVE, GAS 120VAC 3/4" NPT.
5	LOW GAS PRESSURE SWITCH
6	HIGH GAS PRESSURE SWITCH
7	GAS PRESSURE REGULATOR, #RV61, 1", 1 PSI MAX PRES. (SHIPPED LOOSE)
8	LEAKAGE TEST COCK (3)
9	BURNER CAN UNIT
10	HIGH AIR PROVING SWITCH
11	COMBUSTION AIR PROVING SWITCH
12	1" BALL VALVE
13	1" BALL VALVE (SHIPPED LOOSE)
14	PROBE HOLDER
15	TRIDICATOR, TEMP./PRESSURE GAUGE
16	RELIEF VALVE, 3/4" NPT. INLET, (SET AT 125 PSI) (SHIPPED LOOSE)
17	TEMPERATURE THERMAL WELL
18	HW SUPPLY TEMPERATURE/HIGH LIMIT CONTROL SENSOR
19	MIXING VENTURI

ITEM	CUSTOMER CONNECTIONS
A	2-1/2" 150# R.F.FLG. HW SUPPLY SIZE
B	2-1/2" 150# R.F.FLG. HIGH TEMP. RETURN SIZE
C	2-1/2" 150# R.F.FLG. LOW TEMP. RETURN SIZE
D	1" NPT. GAS SUPPLY LINE
E	6" O.D. STACK OUTLET
F	1 1/2" NPT. VENT SIZE
G	1" NPT. RELIEF VALVE OUTLET
H	1/2" NPT. (PLUGGED)
I	1 1/2" NPT. DRAIN (PLUGGED)
J	3/4" FPT. CONDENSATE DRAIN
K	3/4" NPT. (PLUGGED)

SHIPPING DATA	
BOILER HEIGHT: 72.65" (1845 MM)	
BOILER WIDTH: 32.30" (820 MM)	
BOILER DEPTH: 52.45" (1332 MM)	
BOILER WEIGHT: 1,137 LBS.(515 KG)	

BOILER DATA	
FUEL: NATURAL GAS	
INPUT: 750 MBH	
OUTPUT: 690 MBH (92% EFF. NOMINAL)	
MAX. OPERATING TEMPERATURE: 194°F (90°C)	
MINIMUM GAS PRESSURE REQUIRED: 7" W.C.	
MAXIMUM GAS PRESSURE REQUIRED: 28" W.C.	
VOLTAGE: 115/1/60	
HAPS SETTING: 3.5 W.C.	
BOILER WATER VOLUME: NORMAL @ 87 GAL.(329 LITERS)	

- NOTES:**
1. BOILER IS DESIGNED AND CONSTRUCTED IN ACCORDANCE WITH THE ASME BOILER AND PRESSURE VESSEL CODE SECTION IV, WITH "H" STAMP FOR 125# MAWP.
 2. PACKAGED BOILER CERTIFIED FOR cULus LABELED.
 3. ASME CSD-1 COMPLIANT.
 4. UNIT IS FACTORY FIRE TESTED.
 5. BURNER IS FULLY MODULATING WITH 5:1 TURNDOWN.
 6. ALL NORMALLY UNUSED FITTINGS ARE CAPPED OR PLUGGED.
 7. BOILER LEGS ALLOW FOR ADJUSTMENT OF 2.5"
 8. DUE TO UPSWNG OF BURNER FOR SERVICE, DO NOT PIPE ACROSS TOP OF BOILER.
 9. BOILER TO BE FIELD PIPED WITH A 6" MINIMUM CONDENSATE DRAIN TRAP.
 10. PIPE AIR VENT TO EXPANSION TANK OR USE AUTO AIR VENT TUBE.

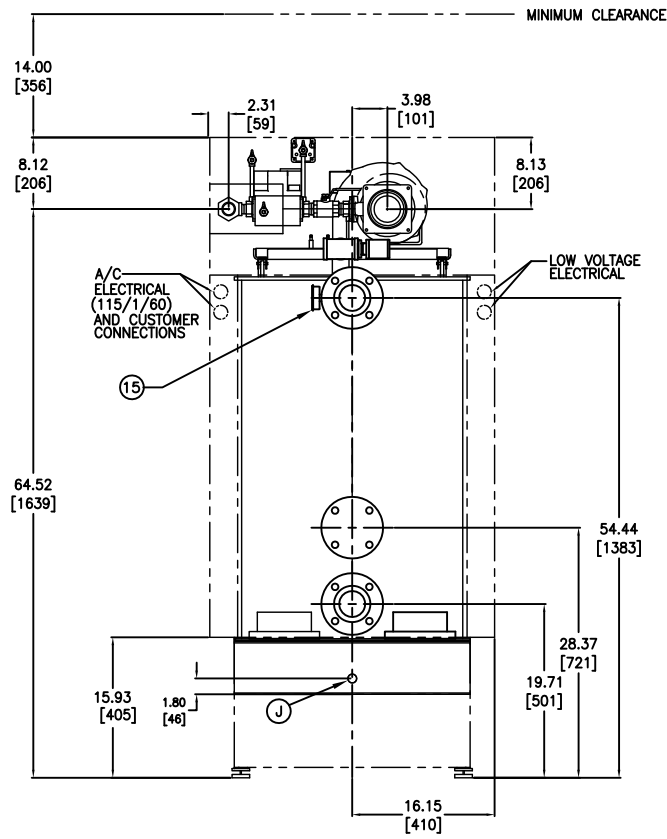
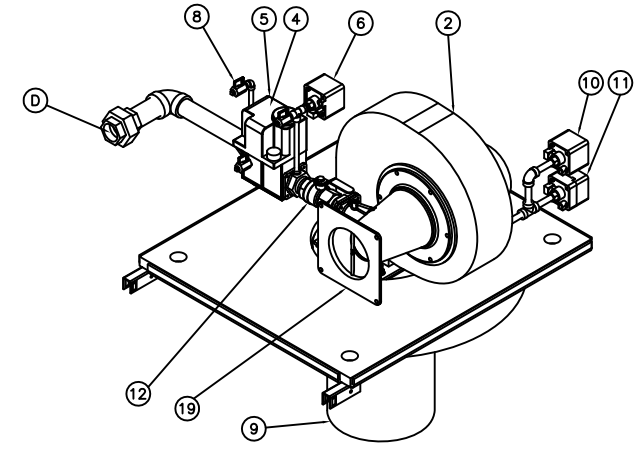
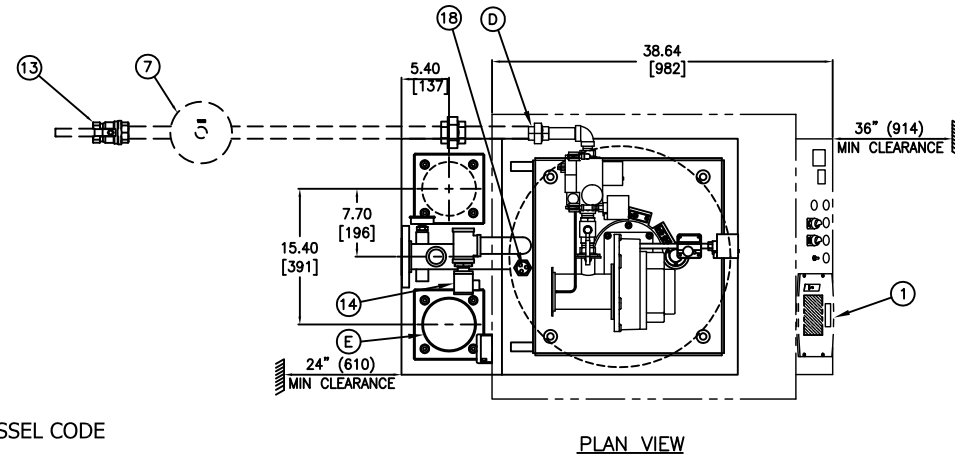

REAR VIEW

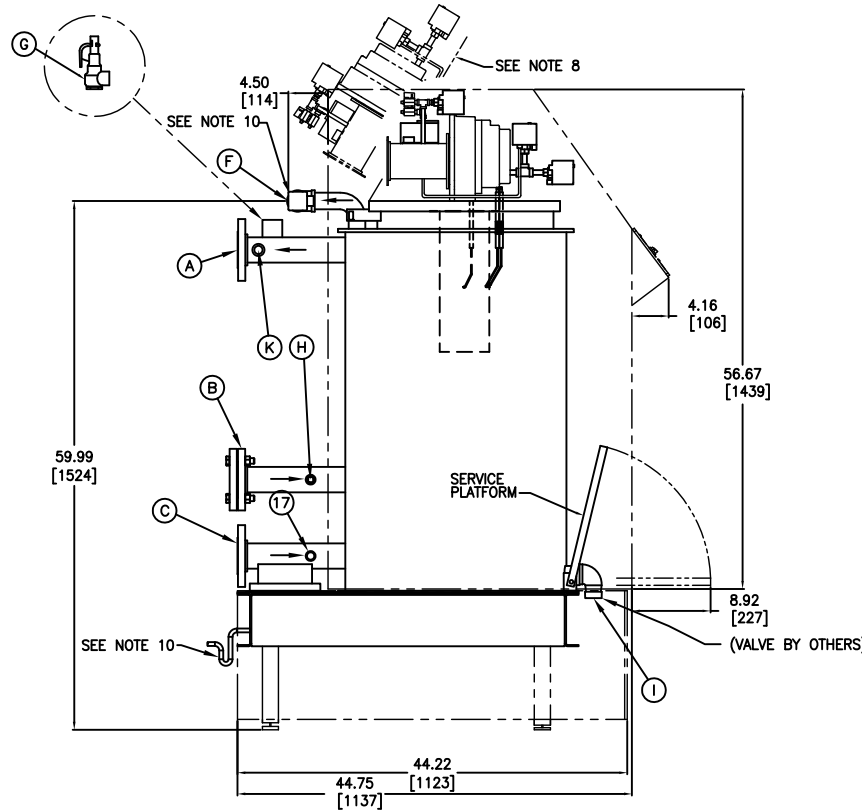

SIDE VIEW

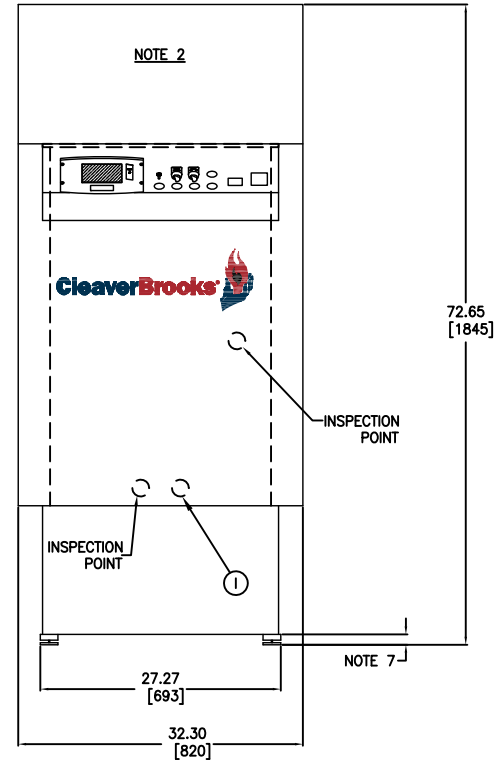

FRONT VIEW

CAUTION

DIMENSIONS SHOWN ARE APPROXIMATE AND SHOULD NOT BE USED IN RESTRICTIVE LAYOUTS OR TO PREFABRICATE ASSEMBLIES UNLESS CLEAVER-BROOKS HAS BEEN CONSULTED. IT IS STRONGLY RECOMMENDED THAT THE CUSTOMER REQUEST AS-BUILT CERTIFIED DRAWINGS FOR THESE CASES.

WARNING:
Changes, modifications or alterations are strictly prohibited.
Changes to this drawing and subsequent modification of equipment could result in damage to the equipment and/or serious personal injury.

DD750CFC

SCALE	N.T.S.			
DATE	06/30/10			
DRAWN	CP			
CHECKED BY	BH			
SIZE	D			
DIMENSION DIAGRAM				
SHT 01 OF 01				

CleaverBrooks			
CFC	700	750	125HW
MODEL	FUEL	SIZE	PRESSURE
115	1	60	2
VOLTS	PHASE	VENTS	WIRE
DRWG. NO. DD750CFC			

THIS DRAWING IS PROPERTY OF CLEAVER-BROOKS DIVISION. IT IS SUBJECT TO CHANGE WITHOUT NOTICE, AND IS NOT TO BE COPIED OR USED IN ANY WAY DETRIMENTAL TO THE COMPANY.

L
D
C
B
A